

## ALTERNATING CURRENT

1. A resistor  $30\ \Omega$ , inductor of reactance  $10\ \Omega$  and capacitor of reactance  $10\ \Omega$  are connected in series to an AC voltage source  $e = 300\sqrt{2}\sin(\omega t)$ . The current in the circuit is
  - a)  $10\sqrt{2}\text{ A}$
  - b)  $10\text{ A}$
  - c)  $30\sqrt{11}\text{ A}$
  - d)  $30/\sqrt{11}\text{ A}$
2. The natural frequency ( $\omega_0$ ) of oscillations in  $L - C$  circuit is given by
  - a)  $\frac{1}{2\pi}\frac{1}{\sqrt{LC}}$
  - b)  $\frac{1}{2\pi}\sqrt{LC}$
  - c)  $\frac{1}{\sqrt{LC}}$
  - d)  $\sqrt{LC}$
3. An ac source of angular frequency  $\omega$  is fed across a resistor  $r$  and a capacitor  $C$  in series. The current registered is  $I$ . If the frequency of source is changed to  $\omega/3$  (maintaining the same voltage), the current in the circuit is found to be halved. Calculate the ratio of reactance to resistance at the original frequency  $\omega$ 
  - a)  $\sqrt{\frac{3}{5}}$
  - b)  $\sqrt{\frac{2}{5}}$
  - c)  $\sqrt{\frac{1}{5}}$
  - d)  $\sqrt{\frac{4}{5}}$
4. When a DC voltage of  $200\text{ V}$  is applied to a coil of self-inductance  $(\frac{2\sqrt{3}}{\pi})\text{ H}$ , a current of  $1\text{ A}$  flows through it. But by replacing DC source with AC source of  $200\text{ V}$ , the current in the coil is reduced to  $0.5\text{ A}$ . Then the frequency of AC supply is
  - a)  $100\text{ Hz}$
  - b)  $75\text{ Hz}$
  - c)  $60\text{ Hz}$
  - d)  $50\text{ Hz}$
5. The power factor of good choke coil is
  - a) Nearly zero
  - b) Exactly zero
  - c) Nearly one
  - d) Exactly one
6. A resistor of  $R = 6\ \Omega$ , an inductor of  $L = 1\text{ H}$  and a capacitor of  $C = 17.36\ \mu\text{F}$  are connected in series with an AC source. Find the  $Q$ -factor.
  - a)  $3.72$
  - b)  $40$
  - c)  $2.37$
  - d)  $80$
7. Power dissipated in an  $LCR$  series circuit connected to an a.c. source of  $emf E$  is
  - a)  $E^2 R / \left[ R^2 + \left( L\omega - \frac{1}{C\omega} \right)^2 \right]$
  - b)  $\frac{E^2 \sqrt{R^2 + \left( L\omega - \frac{1}{C\omega} \right)^2}}{R}$
  - c)  $\frac{E^2 \left[ R^2 + \left( L\omega - \frac{1}{C\omega} \right)^2 \right]}{R}$
  - d)  $\frac{E^2 R}{\sqrt{R^2 + \left( L\omega - \frac{1}{C\omega} \right)^2}}$
8. A virtual current of  $4\text{ A}$  and  $50\text{ Hz}$  flows in an ac circuit containing a coil. The power consumed in the coil is  $240\text{ W}$ . If the virtual voltage across the coil is  $100\text{ V}$  its inductance will be
  - a)  $\frac{1}{3\pi}\text{ H}$
  - b)  $\frac{1}{5\pi}\text{ H}$
  - c)  $\frac{1}{7\pi}\text{ H}$
  - d)  $\frac{1}{9\pi}\text{ H}$
9. A lamp consumes only  $50\%$  of peak power in an a.c. circuit. What is the phase difference between the applied voltage and the circuit current
  - a)  $\frac{\pi}{6}$
  - b)  $\frac{\pi}{3}$
  - c)  $\frac{\pi}{4}$
  - d)  $\frac{\pi}{2}$
10. A vertical ring of radius  $r$  and resistance  $R$  falls vertically. It is in contact with two vertical rails which are joined at the top, figure. The rails are without friction and resistance. There is a horizontal uniform magnetic field of magnitude  $B$  perpendicular to the plane of the ring and the rails. When the speed of the ring is  $v$ , the current in the section  $PQ$  is

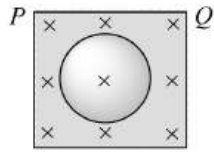



a) Zero

b)  $\frac{2 Rrv}{R}$

c)  $\frac{4 Rrv}{R}$

d)  $\frac{8 Rrv}{R}$

11. Voltage  $V$  and current  $i$  in AC circuit are given by

$V = 50 \sin(50t)$  volt

$i = 50 \sin\left(50t + \frac{\pi}{3}\right)$  mA

The power dissipated in circuit is

a) 5.0 W

b) 2.5 W

c) 1.25 W

d) zero

12. In an LCR series resonant circuit which one of the following cannot be the expression for the Q-factor

a)  $\frac{\omega L}{R}$

b)  $\frac{1}{\omega CR}$

c)  $\sqrt{\frac{L}{C}} \frac{1}{R}$

d)  $\frac{R}{LC}$

13. Which one of the following curves represents the variation of impedance ( $Z$ ) with frequency  $f$  in series LCR circuit

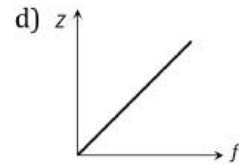
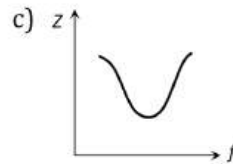
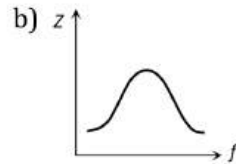
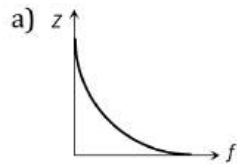

14. The frequency for which a  $5 \mu F$  capacitor has a reactance of  $\frac{1}{1000}$  ohm is given by

a)  $\frac{100}{\pi}$  MHz

b)  $\frac{1000}{\pi}$  Hz

c)  $\frac{1}{1000}$  Hz

d) 1000 Hz

15. The peak value of an alternating current is 5 A and its frequency is 60 Hz. Find its rms value and time taken to reach the peak value of current starting from zero.

a) 3.536 A; 4.167 ms

b) 3.536 A; 15 ms

c) 6.07 A; 10 ms

d) 2.536 A; 4.167 ms

16. The resistance of an R-L circuit is  $10 \Omega$ . An emf  $E_0$  applied across the circuit at  $\omega = 20 \text{ rad s}^{-1}$ . If the current in the circuit is  $\frac{i_0}{\sqrt{2}}$ , what is the value of  $L$ ?

a) 0.5 H

b) 2.25 H

c) 3.9 H

d) 1.0 H

17. In a circuit, the current lags behind the voltage by a phase difference of  $\pi/2$ , the circuit will contain which of the following?

a) Only R

b) Only C

c) R and C

d) Only L

18. In the circuit shown below, the key  $K$  is closed at  $t = 0$ . The current through the battery is

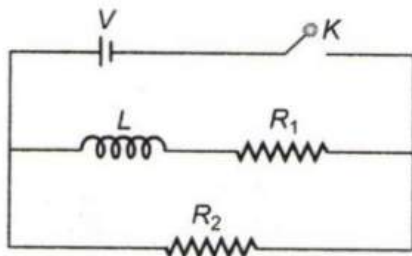

a)  $\frac{VR_1R_2}{\sqrt{R_1^2 + R_2^2}}$  at  $t = 0$  and  $\frac{V}{R_2}$  at  $t = \infty$

b)  $\frac{V}{R_2}$  at  $t = 0$  and  $\frac{V(R_1+R_2)}{R_1R_2}$  at  $t = \infty$

c)  $\frac{V}{R_2}$  at  $t = 0$  and  $\frac{VR_1R_2}{\sqrt{R_1^2 + R_2^2}}$  at  $t = \infty$   
d)  $\frac{V(R_1+R_2)}{R_1R_2}$  at  $t = 0$  and  $\frac{V}{R_2}$  at  $t = \infty$

19. In a circuit, the value of the alternating current is measured by hot wire ammeter as 10 ampere. Its peak value will be  
a) 10 A                                      b) 20 A                                      c) 14.14 A                                      d) 7.07 A
20. In an electrical circuit  $R, L, C$  and an a.c. voltage source are all connected in series. When  $L$  is removed from the circuit, the phase difference between the voltage and the current in the circuit is  $\pi/3$ . If instead,  $C$  is removed from the circuit, the phase difference is again  $\pi/3$ . The power factor of the circuit is  
a)  $1/2$                                       b)  $1/\sqrt{2}$                                       c) 1                                      d)  $\sqrt{3}/2$
21. The power factor of an AC circuit having resistance  $R$  and inductance  $L$  (connected in series) and an angular velocity  $\omega$  is  
a)  $R/\omega L$                                       b)  $R/(R^2 + \omega^2 L^2)^{1/2}$                                       c)  $\omega L/R$                                       d)  $R/(R^2 - \omega^2 L^2)^{1/2}$
22. A uniformly wound solenoidal coil of self inductance  $1.8 \times 10^{-4}$  H and resistance  $6 \Omega$  is broken up into two identical coils. These identical coils are then connected in parallel across a 12 V battery of negligible resistance. The time constant of the current in the circuit and the steady state current through battery is  
a)  $3 \times 10^{-5}$  s, 8 A                                      b)  $1.5 \times 10^{-5}$  s, 8 A                                      c)  $0.75 \times 10^{-4}$  s, 4 A                                      d)  $6 \times 10^{-5}$  s, 2 A
23. An alternating voltage is connected in series with a resistance  $R$  and an inductance  $L$ . If the potential drop across the resistance is 200 V and across the inductance is 150 V, then the applied voltage is  
a) 350 V                                      b) 250 V                                      c) 500 V                                      d) 300 V
24. The number of turns in a secondary coil is twice the number of turns in primary. A leclanche cell of 1.5 V is connected across the primary. The voltage across secondary is  
a) 1.5 V                                      b) 3.0 V                                      c) 240 V                                      d) Zero
25. When the rate of change of current is unity, induced emf is equal to  
a) Thickness of coil                                      b) Number of turns in coil                                      c) Coefficient of self-induction                                      d) Total flux linked with coil
26. A coil of wire of certain radius has 100 turns and a self inductance of 15 mH. The self inductance of a second similar coil of 500 turns will be  
a) 75 mH                                      b) 375 mH                                      c) 15 mH                                      d) None of these
27. The coefficient of induction of a choke coil is 0.1H and resistance is  $12\Omega$ . If it is connected to an alternating current source of frequency 60 Hz, then power factor will be  
a) 0.32                                      b) 0.30                                      c) 0.28                                      d) 0.24
28. A square loop of side  $a$  placed in the same plane as a long straight wire carrying a current  $i$ . The centre of the loop is at a distance  $r$  from the wire, where  $r \gg a$ , figure. The loop is moved away from the wire with a constant velocity  $v$ . The induced emf in the loop is

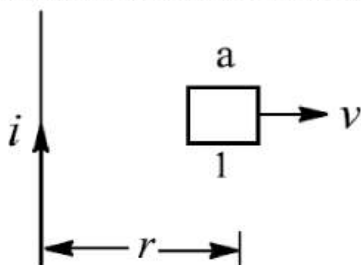

a)  $\frac{\mu_0 i a v}{2 \pi r}$                                       b)  $\frac{\mu_0 i a^3 v}{2 \pi r^3}$                                       c)  $\frac{\mu_0 i v}{2 \pi}$                                       d)  $\frac{\mu_0 i a^2 v}{2 \pi r^2}$

29. Voltage and current in an ac circuit are given by  
 $V = 5 \sin(100\pi t - \frac{\pi}{6})$  and  $I = 4 \sin(100\pi t + \frac{\pi}{6})$   
a) Voltage leads the current by  $30^\circ$   
c) Current leads the voltage by  $60^\circ$

- b) Current leads the voltage by  $30^\circ$   
d) Voltage leads the current by  $60^\circ$

30. A coil is wound on a core of rectangular cross-section. If all the linear dimensions of core are increased by a factor 2 and number of turns per unit length of coil remains same, the self-inductance increases by a factor of
- a) 16                                      b) 8                                      c) 4                                      d) 2
31. The phase angle between *e.m.f.* and current in *LCR* series as circuit is
- a) 0 to  $\frac{\pi}{2}$                                       b)  $\frac{\pi}{4}$                                       c)  $\frac{\pi}{2}$                                       d)  $\pi$
32. The primary winding of a transformer has 200 turns and its secondary winding has 50 turns. If the current in the secondary winding is 40 A, the current in the primary is
- a) 10 A                                      b) 80 A                                      c) 160 A                                      d) 800 A
33. The initial phase angle for  $i = 10 \sin \omega t + 8 \cos \omega t$  is
- a)  $\tan^{-1}\left(\frac{4}{5}\right)$                                       b)  $\tan^{-1}\left(\frac{5}{4}\right)$                                       c)  $\sin^{-1}\left(\frac{4}{5}\right)$                                       d)  $90^\circ$
34. An inductor is connected to an AC source. When compared to voltage, the current in the lead wires
- a) Is ahead in phase by  $\pi$                                       b) Lags in phase by  $\pi$   
c) Is ahead in phase by  $\frac{\pi}{2}$                                       d) Lags in phase by  $\frac{\pi}{2}$
35. An ac supply gives 30 *V r. m. s.* which passes through a  $10 \Omega$  resistance. The power dissipated in it is
- a)  $90\sqrt{2} W$                                       b)  $90 W$                                       c)  $45\sqrt{2} W$                                       d)  $45 W$
36. In a series *LCR* circuit, operated with an ac of angular frequency  $\omega$ , the total impedance is
- a)  $[R^2 + (L\omega - C\omega)^2]^{1/2}$                                       b)  $\left[R^2 + \left(L\omega - \frac{1}{C\omega}\right)^2\right]^{1/2}$   
c)  $\left[R^2 + \left(L\omega - \frac{1}{C\omega}\right)^2\right]^{-1/2}$                                       d)  $\left[(R\omega)^2 + \left(L\omega - \frac{1}{C\omega}\right)^2\right]^{1/2}$
37. An *LCR* series circuit is at resonance. Then
- a) The phase difference between current and voltage is  $90^\circ$   
b) The phase difference between current and voltage is  $45^\circ$   
c) Its impedance is purely resistive  
d) Its impedance is zero
38. The voltage of domestic ac is 220 *volt*. What does the represent
- a) Mean voltage                                      b) Peak voltage  
c) Root mean voltage                                      d) Root mean square voltage
39. In an ideal transformer, the voltage is stepped down from 11 kV to 220 V. If the primary current be 100 A, the current in the secondary should be
- a) 5 kA                                      b) 1 kA                                      c) 0.5 kA                                      d) 0.1 kA
40. If an  $8 \Omega$  resistance and  $6 \Omega$  reactance are present in an ac series circuit then the impedance of the circuit will be
- a) 20 *ohm*                                      b) 5 *ohm*                                      c) 10 *ohm*                                      d)  $14\sqrt{2}$  *ohm*
41. An alternating current of frequency '*f*' is flowing in a circuit containing a resistance *R* and a choke *L* in series. The impedance of this circuit is
- a)  $R + 2\pi fL$                                       b)  $\sqrt{R^2 + 4\pi^2 f^2 L^2}$                                       c)  $\sqrt{R^2 + L^2}$                                       d)  $\sqrt{R^2 + 2\pi fL}$
42. The process by which ac is converted into dc is known as
- a) Purification                                      b) Amplification                                      c) Rectification                                      d) Current amplification
43. The frequency of an alternating voltage is 50 *cycles/sec* and its amplitude is 120V. Then the *r. m. s.* value of voltage is
- a) 101.3V                                      b) 84.8V                                      c) 70.7V                                      d) 56.5V
44. An inductor ( $L = 100 \text{ mH}$ ), a resistor ( $R = 100 \Omega$ ) and a battery ( $E = 100 \text{ V}$ ) are initially connected in series as shown in figure. After a long time the battery is disconnected after short circuiting the points *A* and *B*.  
The current in the circuit 1 ms after the short circuit is

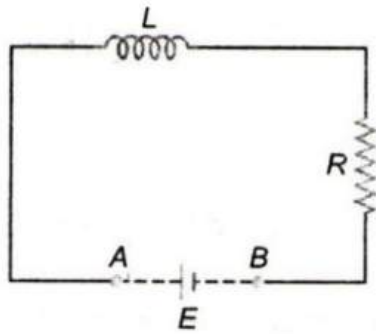

- a)  $1/e A$                       b)  $e A$                       c)  $0.1 A$                       d)  $1 A$
45.  $\frac{R}{L}$  has the dimensions to  
 a) Time                      b) Mass                      c) Length                      d) Frequency
46. The instantaneous values of current and emf in an ac circuit are  $I = 1/\sqrt{2} \sin 314 t$  amp and  $E = \sqrt{2} \sin(314 t - \pi/6)$  V respectively. The phase difference between  $E$  and  $I$  will be  
 a)  $-\pi/6$  rad                      b)  $-\pi/3$  rad                      c)  $\pi/6$  rad                      d)  $\pi/3$  rad
47. The variation of the instantaneous current ( $I$ ) and the instantaneous emf ( $E$ ) in a circuit is as shown in fig. Which of the following statements is correct

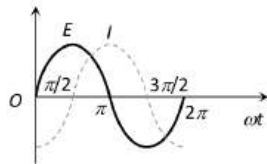

- a) The voltage lags behind the current by  $\pi/2$                       b) The voltage leads the current by  $\pi/2$   
 c) The voltage and the current are in phase                      d) The voltage leads the current by  $\pi$
48. In a  $L - R$  circuit, the value of  $L$  is  $(\frac{0.4}{\pi})$  H and the value of  $R$  is  $30 \Omega$ . If in the circuit, an alternating emf of  $200 V$  at  $50$  cycle/s is connected, the impedance of the circuit and current will be  
 a)  $11.4 \Omega, 17.5 A$                       b)  $30.7 \Omega, 6.5 A$                       c)  $40.4 \Omega, 5 A$                       d)  $50 \Omega, 4 A$
49. In an A.C. circuit the current  
 a) Always leads the voltage                      b) Always lags behind the voltage  
 c) Is always in phase with the voltage                      d) May lead or lag behind or be in phase with the voltage
50. A  $100 V$ , AC source of frequency  $500 Hz$  is connected to an  $L-C-R$  circuit with  $L=8.1 mH, C = 12.5 \mu F, R = 10 \Omega$  all connected in series as shown in figure. What is the quality factor of circuit?

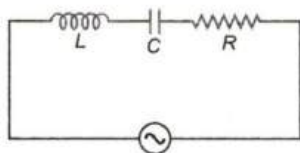

- a) 2.02                      b) 2.5434                      c) 20.54                      d) 200.54
51. A constant voltage at different frequencies is applied across a capacitance  $C$  as shown in the figure. Which of the following graphs correctly depicts the variation of current with frequency

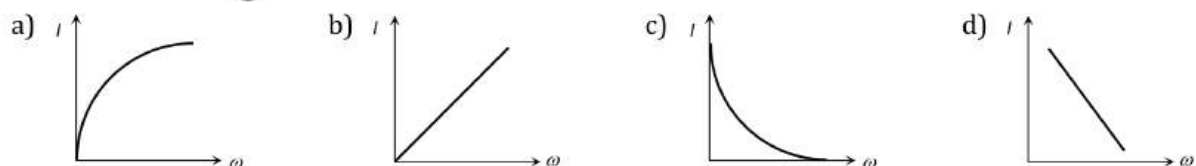
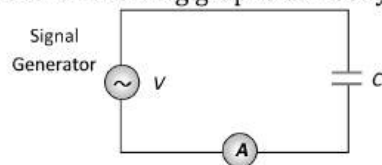

52. If the value of potential in an ac circuit is  $10V$ , then the peak value of potential is

- a)  $\frac{10}{\sqrt{2}}$                       b)  $10\sqrt{2}$                       c)  $20\sqrt{2}$                       d)  $\frac{20}{\sqrt{2}}$

53. In the circuit shown in figure switch  $S$  is closed at time  $t = 0$ . The charge which passes through the battery in one time constant is

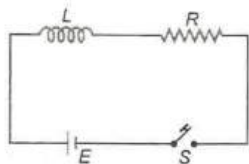

- a)  $\frac{EL}{eR^2}$                       b)  $\frac{eL}{ER}$                       c)  $\frac{eR^2E}{L}$                       d)  $E\left(\frac{L}{R}\right)$

54. A transformer is used to light  $140\text{ W}$ ,  $24\text{ V}$  lamp from  $240\text{ V}$  AC mains. The current in the mains is  $0.7\text{ A}$ . The efficiency of transformer is nearest to

- a) 90%                      b) 80%                      c) 70%                      d) 60%

55. In an  $L - R$  circuit to a battery, the rate at which energy is stored in the inductor is plotted against time during the growth of current in the circuit. Which of the following, figure best represents the resulting curve?

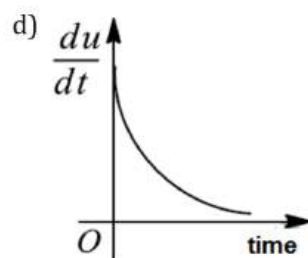
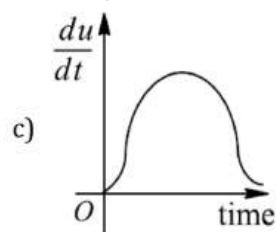
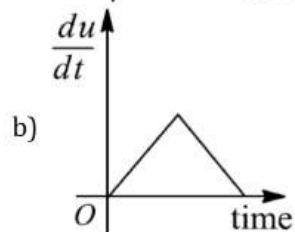
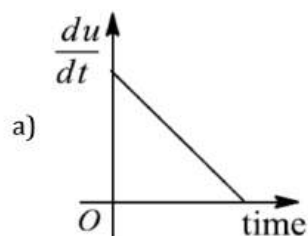

56. An ac source is rated at  $220V$ ,  $50\text{ Hz}$ . The time taken for voltage to change from its peak value to zero is

- a)  $50\text{ sec}$                       b)  $0.02\text{ sec}$                       c)  $5\text{ sec}$                       d)  $5 \times 10^{-3}\text{ sec}$

57. The maximum voltage in DC circuit is  $282V$ . The effective voltage in AC circuit will be

- a)  $200\text{ V}$                       b)  $300\text{ V}$                       c)  $400\text{ V}$                       d)  $564\text{ V}$

58. The capacity of a pure capacitor is  $1\text{ farad}$ . In dc circuits, its effective resistance will be

- a) Zero                      b) Infinite                      c)  $1\text{ ohm}$                       d)  $1/2\text{ ohm}$

59. An inductive circuit contains a resistance of  $10\ \text{ohm}$  and an inductance of  $2.0\ \text{henry}$ . If an ac voltage of  $120\ \text{volt}$  and frequency of  $60\ \text{Hz}$  is applied to this circuit, the current in the circuit would be nearly
- a)  $0.32\ \text{amp}$                       b)  $0.16\ \text{amp}$                       c)  $0.48\ \text{amp}$                       d)  $0.80\ \text{amp}$
60. The time taken by an alternating current of  $50\ \text{Hz}$  in reaching from zero to its maximum value will be
- a)  $0.5\ \text{s}$                               b)  $0.005\ \text{s}$                       c)  $0.05\ \text{s}$                       d)  $5\ \text{s}$
61. If coefficient of self induction of a coil is  $1\ \text{H}$ , an emf of  $1\ \text{V}$  is induced, if
- a) Current flowing is  $1\ \text{A}$                       b) Current variation rate is  $1\ \text{As}^{-1}$   
c) Current of  $1\ \text{A}$  flows for one sec                      d) None of the above
62. A parallel plate capacitor  $C$  with plates of unit area and separation  $d$  is filled with a liquid of dielectric constant  $K=2$ . The level of liquid is  $\frac{d}{3}$  initially. Suppose the liquid level decreases at a constant speed  $v$ , the time constant as a function of time  $t$  is.

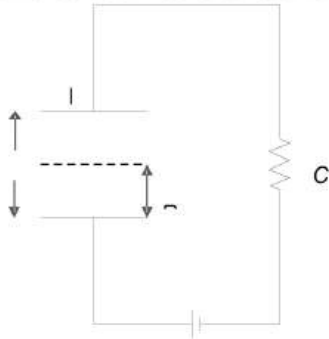

- a)  $\frac{6\epsilon_0 R}{5d + 3vt}$                       b)  $\frac{(15d + 9vt)\epsilon_0 R}{2d^2 - 3dvt - 9v^2 t^2}$                       c)  $\frac{6\epsilon_0 R}{5d - 3vt}$                       d)  $\frac{(15d - 9vt)\epsilon_0 R}{2d^2 + 3dvt - 9v^2 t^2}$

63. If the coils of a transformer are made up of thick wire, then
- a) Eddy currents loss will be more                      b) Magnetic flux leakage is reduced  
c) Joule's heating loss is increased                      d) Joule's heating loss is reduced
64. The peak value of  $220\ \text{volts}$  of ac mains is
- a)  $155.6\ \text{volts}$                       b)  $220.0\ \text{volts}$                       c)  $311.0\ \text{volts}$                       d)  $440\ \text{volts}$
65. An alternating emf is applied across a parallel combination of a resistance  $R$ , capacitance  $C$  and an inductance  $L$ . If  $I_R, I_L, I_C$  are the current through  $R, L$  and  $C$  respectively, then the diagram which correctly represents the phase relationship among  $I_R, I_L, I_C$  and source emf  $E$ , is given by

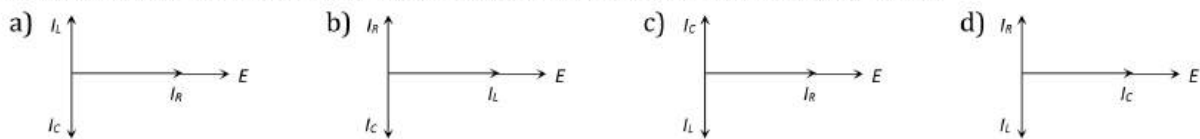

66. The time constant of the given circuit is

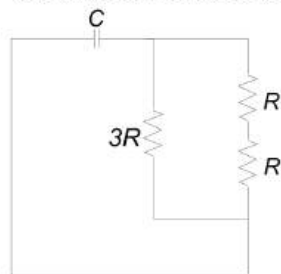

- a)  $\frac{3RC}{5}$                               b)  $\frac{6RC}{5}$                               c)  $\frac{5RC}{6}$                               d) None of these

67. A solenoid has  $2000$  turns wound over a length of  $0.30\ \text{m}$ . The area of its cross section is  $1.2 \times 10^{-3}\ \text{m}^2$ . Around its central section, a coil of  $300$  turns is wound. If an initial current of  $2\ \text{A}$  in the solenoid is reversed in  $0.25\ \text{s}$ , then the emf induced in the coil is equal to
- a)  $6 \times 10^{-4}\ \text{V}$                       b)  $4.8 \times 10^{-2}\ \text{V}$                       c)  $6 \times 10^{-2}\ \text{V}$                       d)  $48\ \text{kV}$

68. The potential difference  $V$  and the current  $i$  flowing through an instrument in an ac circuit of frequency  $f$  are given by  $V = 5 \cos \omega t$  volts and  $I = 2 \sin \omega t$  amperes (where  $\omega = 2\pi f$ ). The power dissipated in the instrument is  
 a) Zero                                      b) 10 W                                      c) 5 W                                      d) 2.5 W
69. An e.m.f.  $E = 4 \cos(1000t)$  volt is applied to an LR-circuit of inductance 3 mH and resistance 4 ohms. The amplitude of current in the circuit is  
 a)  $\frac{4}{\sqrt{7}}$  A                                      b) 1.0 A                                      c)  $\frac{4}{7}$  A                                      d) 0.8 A
70. A coil of inductive reactance  $31\Omega$  has a resistance of  $8\Omega$ . It is placed in series with a condenser of capacitive reactance  $25\Omega$ . The combination is connected to an a.c. source of 110 volt. The power factor of the circuit is  
 a) 0.80                                      b) 0.33                                      c) 0.56                                      d) 0.64
71. The expression for magnetic induction inside a solenoid of length  $L$ , carrying a current  $i$  and having  $N$  number of turns is  
 a)  $\frac{\mu_0 N}{4\pi L} i$                                       b)  $\mu_0 N L i$                                       c)  $\frac{\mu_0}{4\pi} N L i$                                       d)  $\mu_0 \frac{N^2}{L} i$
72. In an LR-circuit, the inductive reactance is equal to the resistance  $R$  of the circuit. An e.m.f.  $E = E_0 \cos(\omega t)$  is applied to the circuit. The power consumed in the circuit is  
 a)  $\frac{E_0^2}{R}$                                       b)  $\frac{E_0^2}{2R}$                                       c)  $\frac{E_0^2}{4R}$                                       d)  $\frac{E_0^2}{8R}$
73. In an AC circuit, the current lags behind the voltage by  $\pi/3$ . The components of the circuit are  
 a)  $R$  and  $L$                                       b)  $L$  and  $C$                                       c)  $R$  and  $C$                                       d) Only  $R$
74. The instantaneous value of current in an A.C. circuit is  $I = 2 \sin(100\pi t + \pi/3)$  A. The current will be maximum for the first time at  
 a)  $t = \frac{1}{100}$  s                                      b)  $t = \frac{1}{200}$  s                                      c)  $t = \frac{1}{400}$  s                                      d)  $t = \frac{1}{600}$  s
75. A resistor  $R$ , an inductor  $L$  and a capacitor  $C$  are connected in series to an oscillator of frequency  $n$ , if the resonant frequency is  $n_r$ , then the current lags behind voltage, when  
 a)  $n = 0$                                       b)  $n < n_r$                                       c)  $n = n_r$                                       d)  $n > n_r$
76. During a current change from 2 A to 4 A in 0.05 s, 8 V of emf is developed in a coil. The coefficient of self-induction is  
 a) 0.1 H                                      b) 0.2 H                                      c) 0.4 H                                      d) 0.8 H
77. In an  $L - R$  circuit shown in above figure switch S is closed at time  $t = 0$ . If  $e$  denotes the induced emf across inductor and  $i$ , the current in the circuit at any time  $t$ , then which of the following graphs, figure shows the variation of  $e$  with  $i$ ?



78. Let  $C$  be the capacitance of a capacitor discharging through a resistor  $R$ . Suppose  $t_1$  is the time taken for the energy stored in the capacitor to reduce to half its initial value and  $t_2$  is the time taken for the charge to reduce to one-fourth its initial value. Then the ratio  $\frac{t_1}{t_2}$  will be  
 a) 1                                      b)  $\frac{1}{2}$                                       c)  $\frac{1}{4}$                                       d) 2
79. The phase difference between the current and voltage of LCR circuit in series combination at resonance is  
 a) 0                                      b)  $\pi/2$                                       c)  $\pi$                                       d)  $-\pi$
80. The impedance of a circuit consists of 3 ohm resistance and 4 ohm reactance. The power factor of the circuit is  
 a) 0.4                                      b) 0.6                                      c) 0.8                                      d) 1.0



81. A 220 V, 50 Hz ac source is connected to an inductance of 0.2 H and a resistance of 20 ohm in series. What is the current in the circuit  
 a) 10 A                      b) 5 A                      c) 33.3 A                      d) 3.33 A
82. A transformer is having 2100 turns in primary and 4200 turns in secondary. An AC source of 120 V, 10 A is connected to its primary. The secondary voltage and current are  
 a) 240 V, 5 A                      b) 120 V, 10 A                      c) 240 V, 10 A                      d) 120 V, 20 A
83. If instantaneous current is given by  $i = 4 \cos(\omega t + \phi)$  amperes, then the r. m. s value of current is  
 a) 4 amperes                      b)  $2\sqrt{2}$  amperes                      c)  $4\sqrt{2}$  amperes                      d) Zero amperes
84. When an AC source of emf  $e = E_0 \sin(100t)$  is connected across a circuit, the phase difference between the emf  $e$  and the current  $i$  in the circuit is observed to be  $\frac{\pi}{4}$ , as shown in the diagram. If the circuit consists possibly only of R - C or R - L or L - C in series, find the relationship between the two elements

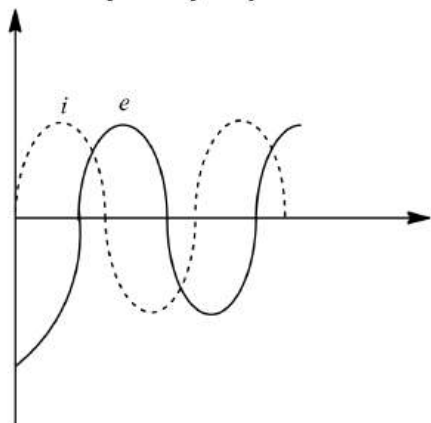

- a)  $R = 1 \text{ k}\Omega, C = 10 \mu\text{F}$     b)  $R = 1 \text{ k}\Omega, C = 1 \mu\text{F}$     c)  $R = 1 \text{ k}\Omega, L = 10 \text{ H}$     d)  $R = 1 \text{ k}\Omega, L = 1 \text{ H}$
85. If a current  $I$  given by  $I_0 \sin\left(\omega t - \frac{\pi}{2}\right)$  flows in an ac circuit across, which an ac potential of  $E = E_0 \sin \omega t$  has been applied, then the power consumption  $P$  in the circuit will be  
 a)  $P = \frac{E_0 I_0}{\sqrt{2}}$                       b)  $P = \sqrt{2} E_0 I_0$                       c)  $P = \frac{E_0 I_0}{2}$                       d)  $P = 0$
86. A resistance  $R$ , inductance  $L$  and capacitor  $C$  are connected in series to an oscillator of frequency  $f$ . If resonant frequency is  $f_r$ , then current will lag the voltage when  
 a)  $f = 0$                       b)  $f < f_r$                       c)  $f = f_r$                       d)  $f > f_r$
87. A generator produces a voltage that is given by  $V = 240 \sin 120 t$ , where  $t$  is in seconds. The frequency and r. m. s. voltage are  
 a) 60 Hz and 240 V                      b) 19 Hz and 120 V                      c) 19 Hz and 170 V                      d) 754 Hz and 70 V
88. A 50 V AC is applied across an R-C (series) network. The rms voltage across the resistance is 40 V, then the potential across the capacitance would be  
 a) 10 V                      b) 20 V                      c) 30 V                      d) 40 V
89. An alternating voltage  $e = 200 \sin 100 t$  is applied to a series combination  $R = 30 \Omega$  and an inductor of 400 mH. The power factor of the circuit is  
 a) 0.01                      b) 0.2                      c) 0.05                      d) 0.6
90. Is it possible

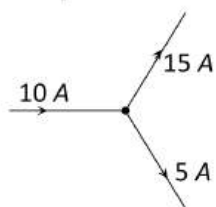

- a) Yes                      b) No  
 c) Cannot be predicted                      d) Insufficient data to reply

91. The figure shows variation of  $R$ ,  $X_L$  and  $X_C$  with frequency  $f$  in a series  $L, C, R$  circuit. Then for what frequency  $f$  in a series  $L, C, R$  circuit. Then for what frequency point, the circuit is inductive

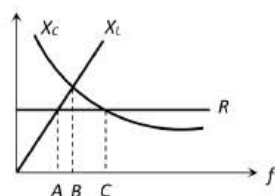

- a) A                                      b) B                                      c) C                                      d) All points
92. In the inductive circuit given in the figure, the current rises after the switch is closed. At instant when the current is  $15\text{ mA}$ , then potential difference across the inductor will be

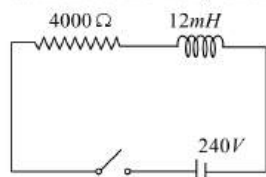

- a) Zero                                      b)  $240V$                                       c)  $180V$                                       d)  $60V$
93. If  $L$  and  $R$  represent inductance and resistance respectively, then dimension of  $L/R$  will be
- a)  $[ML^0T^0]$                                       b)  $[M^0L^0T^{-1}]$                                       c)  $[M^0L^0T^{-2}]$                                       d)  $[M^0LT^{-2}]$
94. Two identical incandescent light bulbs are connected as shown in figure. When the circuit is an AC voltage source of frequency  $f$ , which of the following observation will be correct

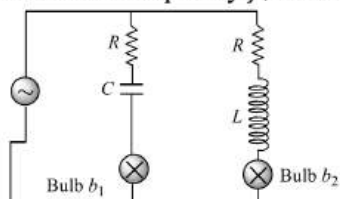

- a) Both bulbs will glow alternatively
- b) Both bulbs will glow with same brightness provided  $f = \frac{1}{2\pi} \sqrt{(1/LC)}$
- c) Bulb  $b_1$  will light up initially and goes off, bulb  $b_2$  will be ON constantly
- d) Bulb  $b_1$  will blink and bulb  $b_2$  will be ON constantly
95. When a coil carrying a steady current is short circuited, the current in it, decreases  $\eta$  time in time  $t_0$ . The time constant of the circuit is
- a)  $\frac{t_0}{\ln \eta}$                                       b)  $\frac{t_0}{\eta - 1}$                                       c)  $t_0 \ln \eta$                                       d)  $\frac{t_0}{\eta}$
96. Following figure shows an ac generator connected to a "block box" through a pair of terminals. The box contains possible  $R, L, C$  or their combination, whose elements and arrangements are not known to us. Measurements outside the box reveals t

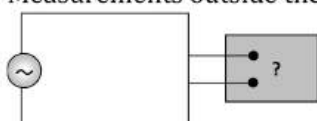

$$e = 75 \sin(\sin \omega t) \text{ volt,}$$

$$i = 1.5 \sin(\omega t + 45^\circ) \text{ amp. The wrong statement is}$$

- a) There must be a capacitor in the box                                      b) There must be an inductor in the box
- c) There must be a resistance in the box                                      d) The power factor is 0.707
97. An  $L - C - R$  circuit of  $R = 100 \Omega$  is connected to an AC source  $100\text{ V}$ ,  $50\text{ Hz}$ . The magnitude of phase difference between current and voltage is  $30^\circ$ . The power dissipated in the  $L - C - R$  circuit is
- a)  $50\text{ W}$                                       b)  $86.6\text{ W}$                                       c)  $100\text{ W}$                                       d)  $200\text{ W}$
98. In a circuit  $L, C$  and  $R$  are connected in series with an alternating voltage source of frequency  $f$ . The current leads the voltage by  $45^\circ$ . The value of  $C$  is



a)  $\frac{1}{2\pi f (2\pi fL + R)}$       b)  $\frac{1}{\pi f (2\pi fL + R)}$       c)  $\frac{1}{2\pi f (2\pi fL - R)}$       d)  $\frac{1}{\pi f (2\pi fL - R)}$

99. If the total charge stored in the LC circuit is  $Q_0$ , then for  $t \geq 0$

- a) The charge on the capacitor is  $Q = Q_0 \cos\left(\frac{\pi}{2} + \frac{t}{\sqrt{LC}}\right)$   
 b) The charge on the capacitor is  $Q = Q_0 \cos\left(\frac{\pi}{2} - \frac{t}{\sqrt{LC}}\right)$   
 c) The charge on the capacitor is  $Q = -LC \frac{d^2Q}{dt^2}$   
 d) The charge on the capacitor is  $Q = \frac{1}{\sqrt{LC}} \frac{d^2Q}{dt^2}$

100. In  $L - C - R$  series circuit the resonance condition in terms of capacitive reactance ( $X_C$ ) and inductive reactance ( $X_L$ ) is

- a)  $X_C + X_L = 0$       b)  $X_C = 0$       c)  $X_L = 0$       d)  $X_C - X_L = 0$

101. What is the average value of the AC voltage over one complete cycle?

- a) Zero      b)  $V_{\max}$       c)  $\frac{2V_{\max}}{\pi}$       d)  $\frac{V_{\max}}{2}$

102. A current of 10 A in the primary coil of a circuit is reduced to zero. If the coefficient of mutual inductance is 3H and emf induced in secondary coil is 30 kV, time taken for the change of current is

- a)  $10^3$  s      b)  $10^2$  s      c)  $10^{-3}$  s      d)  $10^{-2}$  s

103. A square metal wire loop PQRS of side 10 cm and resistance  $1 \Omega$  is moved with a constant velocity  $v_c$  in a uniform magnetic field of induction  $B = 2 \text{ Wbm}^2$ , as shown in figure. The magnetic field lines are perpendicular to the plane of the loop (directed into the paper). The loop is connected to network ABCD of resistors each of value  $3 \Omega$ . The resistance of the lead wires SB and RD are negligible. The speed of the loop so as to have a steady current of mA in the loop is

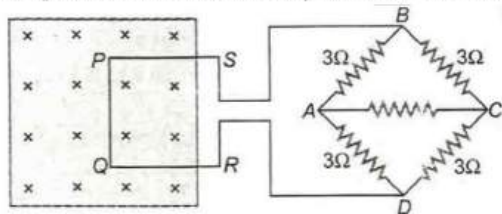

- a)  $2 \text{ ms}^{-1}$       b)  $2 \times 10^{-2} \text{ ms}^{-1}$       c)  $20 \text{ ms}^{-1}$       d)  $200 \text{ ms}^{-1}$

104. A conducting rod PQ of length  $L = 1.0 \text{ m}$  is moving with a uniform speed  $v = 2.0 \text{ ms}^{-1}$  in a uniform magnetic field  $= 4.0 \text{ T}$  directed into the paper. A capacitor of capacity  $C = 10 \mu\text{F}$  is connected as shown in figure. Then,

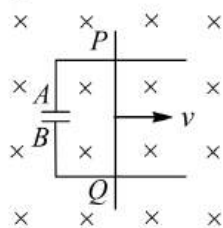

- a)  $q_A = -80 \mu\text{C}$  and  $q_B = +80 \mu\text{C}$       b)  $q_A = +80 \mu\text{C}$  and  $q_B = -80 \mu\text{C}$   
 c)  $q_A = 0 = q_B$       d) Charge stored in the capacitor increases exponentially with time

105. For a large industrial city with much load variations, the DC generator should be

- a) Series wound      b) Shunt wound      c) Mixed wound      d) Any

106. The self inductance of the motor of an electric fan is  $10\text{H}$ . In order to impart maximum power at  $50 \text{ Hz}$ , it should be connected to a capacitance of

- a)  $1 \mu\text{F}$       b)  $2 \text{ mF}$       c)  $4 \text{ mF}$       d)  $8 \text{ mF}$

107. In  $L - C - R$  circuit, an alternating emf of angular frequency  $\omega$  is applied then the total impedance will be

$$a) \left[ (R\omega)^2 + \left( L\omega - \frac{1}{C\omega} \right)^2 \right]^{1/2}$$

$$b) \left[ R^2 + \left( L\omega - \frac{1}{C\omega} \right)^2 \right]^{-1/2}$$

$$c) [R^2 + (L\omega - C\omega)^2]^{1/2}$$

$$d) \left[ R^2 + \left( L\omega - \frac{1}{C\omega} \right)^2 \right]^{1/2}$$

108.  $\frac{2.5}{\pi} \mu F$  capacitor and 3000-ohm resistance are joined in series to an ac source of 200 volt and  $50 \text{ sec}^{-1}$  frequency. The power factor of the circuit and the power dissipated in it will respectively be  
 a) 0.6, 0.06 W                      b) 0.06, 0.6 W                      c) 0.6, 4.8 W                      d) 4.8, 0.6 W

109. For series LCR circuit, wrong statement is

- a) Applied e.m.f. and potential difference across resistance are in same phase  
 b) Applied e.m.f. and potential difference at inductor coil have phase difference of  $\pi/2$   
 c) Potential difference at capacitor and inductor have phase difference of  $\pi/2$   
 d) Potential difference across resistance and capacitor have phase difference of  $\pi/2$

110. An ideal coil of 10 H is connected in series with a resistance of  $5 \Omega$  and a battery of 5 V. 2s after the connection is made, the current flowing (in ampere) in the circuit is

- a)  $(1 - e)$                       b)  $e$                       c)  $e^{-1}$                       d)  $(1 - e^{-1})$

111. If a current of 3 A flowing in the primary coil is reduced to zero in 0.001 s, the induced emf in between the two coils is 15000 V, the coefficient of mutual induction is

- a) 0.5 H                      b) 5 H                      c) 1.5 H                      d) 10 H

112. The power factor of LCR circuit at resonance is

- a) 0.707                      b) 1                      c) Zero                      d) 0.5

113. At time  $t = 0$ , a battery of 10 V is connected across points A and B in the given circuit. If the capacitors have no charge initially, at what time (in second) does the voltage across them become 4 V?  
 (Take  $\ln 5 = 1.6$ ,  $\ln 3 = 1.1$ )

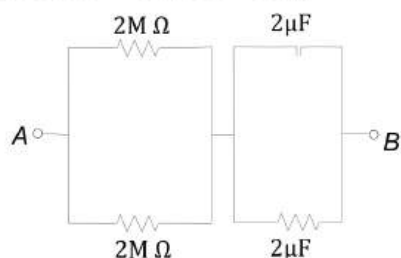

- a) 2                      b) 3                      c) 2.5                      d)  $\frac{3}{2}$

114. An air cored coil has a self-inductance of 0.1 H. A soft iron core of relative permeability 100 is  $1/10$ th. The value of self-inductance now becomes

- a) 1 mH                      b) 10 mH                      c) 0.4 H                      d) 0.8 H

115. The armature of a shunt wound motor can with stand current up to 8A before it overheats and it damaged. If the armature resistance is  $0.5 \Omega$ , minimum back emf that must be motor is connected to a 120 V line is

- a) 120 V                      b) 116 V                      c) 124 V                      d) 4 V

116. In the circuit shown below what will be the readings of the voltmeter and ammeter? (Total impedance of circuit  $Z = 100 \Omega$ )

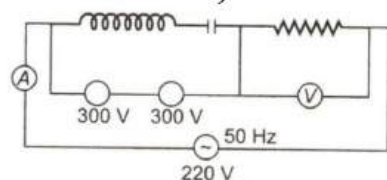

- a) 200 V, 1 A                      b) 800 V, 2 A                      c) 100 V, 2 A                      d) 220 V, 2.2 A

117. In the non-resonant circuit, what will be the nature of the circuit for frequencies higher than the resonant frequency

- a) Resistive                      b) Capacitive                      c) Inductive                      d) None of the above
118. In AC circuit a resistance of  $R \Omega$  is connected in series with an inductance  $L$ . If the phase difference between the current and voltage is  $45^\circ$ , the inductive reactance will be  
a)  $R/2$                       b)  $R/4$                       c)  $R$                       d) None of the above
119. The current in series  $LCR$  circuit will be maximum when  $\omega$  is  
a) As large as possible                      b) Equal to natural frequency of  $LCR$  system  
c)  $\sqrt{LC}$                       d)  $\sqrt{1/LC}$
120. Two conducting circular loops of radii  $R_1$  and  $R_2$  are placed in the same plane with their centres coinciding. If  $R_1 > R_2$ , the mutual inductance  $M$  between them will be directly proportional to  
a)  $\frac{R_1}{R_2}$                       b)  $\frac{R_2}{R_1}$                       c)  $\frac{R_1^2}{R_2}$                       d)  $\frac{R_2^2}{R_1}$
121. Which of the following quantities remains constant in a step-down transformer ?  
a) Current                      b) Voltage                      c) Power                      d) None of these
122. The voltage of an ac source varies with time according to the equation  $V = 100 \sin 100\pi t \cos 100\pi t$  where  $t$  is in second and  $V$  is in volts. Then  
a) The peak voltage of the source is 100 volts  
b) The peak voltage of the source is 50 volts  
c) The peak voltage of the source is  $100/\sqrt{2}$  volts  
d) The frequency of the source is 50 Hz
123. At high frequency, the capacitor offer  
a) More reactance                      b) Less reactance                      c) Zero reactance                      d) Infinite reactance
124. A circuit has a resistance of  $12 \Omega$  and an impedance of  $15 \Omega$ . The power factor of the circuit will be  
a) 0.8                      b) 0.4                      c) 1.25                      d) 0.125
125. An inductance of  $1 \text{ mH}$  a condenser of  $10 \mu\text{F}$  and a resistance of  $50 \Omega$  are connected in series. The reactances of inductor and condensers are same. The reactance of either of them will be  
a)  $100 \Omega$                       b)  $30 \Omega$                       c)  $3.2 \Omega$                       d)  $10 \Omega$
126. The current flowing in a step down transformer 220 V to 22 V having impedance  $220 \Omega$  is  
a) 1 A                      b) 0.1 A                      c) 2 mA                      d) 0.1 mA
127. If  $E = 100 \sin(100t)$  volt and  $I = 100 \sin\left(100t + \frac{\pi}{3}\right)$  mA are the instantaneous values of voltage and current, then the r. m. s. values of voltage and current are respectively  
a) 70.7V, 70.7mA                      b) 70.7V, 70.7A                      c) 141.4V, 141.4mA                      d) 141.4V, 141.4A
128. An ideal choke draws a current of 8 A when connected to an AC supply of 100 V, 50 Hz. A pure resistor draws a current of 10 A when connected to the same source. The ideal choke and the resistor are connected in series and then connected to the AC source of 150 V, 40 Hz. The current in the circuit becomes  
a)  $\frac{15}{\sqrt{2}}$  A                      b) 8 A                      c) 18 A                      d) 10 A

129. If  $A$  and  $B$  are identical bulbs, which bulb glows brighter

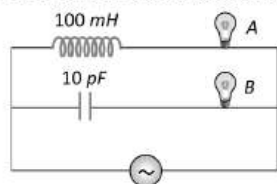

- a)  $A$                       b)  $B$                       c) Both equally bright                      d) Cannot say
130. A  $280 \text{ ohm}$  electric bulb is connected to 200V electric line. The peak value of current in the bulb will be  
a) About one ampere                      b) Zero                      c) About two ampere                      d) About four ampere
131. If  $E_0$  represents the peak value of the voltage in an ac circuit, the r. m. s value of the voltage will be  
a)  $\frac{E_0}{\pi}$                       b)  $\frac{E_0}{2}$                       c)  $\frac{E_0}{\sqrt{\pi}}$                       d)  $\frac{E_0}{\sqrt{2}}$

132. In  $L - R$  circuit, resistance is  $8 \Omega$  and inductive reactance is  $6 \Omega$ , then impedance is  
 a)  $2 \Omega$                       b)  $14 \Omega$                       c)  $4 \Omega$                       d)  $10 \Omega$
133. The root mean square value of the alternating current is equal to  
 a) Twice the peak value                      b) Half the peak value  
 c)  $\frac{1}{\sqrt{2}}$  times the peak value                      d) Equal to the peak value
134. What will be the phase difference between virtual voltage and virtual current, when the current in the circuit is wattless  
 a)  $90^\circ$                       b)  $45^\circ$                       c)  $180^\circ$                       d)  $60^\circ$
135. Power factor is maximum in an  $LCR$  circuit when  
 a)  $X_L = X_C$                       b)  $R = 0$                       c)  $X_L = 0$                       d)  $X_C = 0$
136. The output current versus time curve of a rectifier is shown in the figure. The average value of output current in this case is

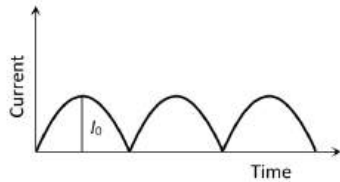

- a) 0                      b)  $\frac{I_0}{2}$                       c)  $\frac{2I_0}{\pi}$                       d)  $I_0$
137. In a series resonant  $L - C - R$  circuit, the voltage across  $R$  is  $100 \text{ V}$  and  $R = 1 \text{ k}\Omega$  with  $C = 2 \mu\text{F}$ . The resonant frequency  $\omega$  is  $200 \text{ rads}^{-1}$ . At resonance the voltage across  $L$  is  
 a)  $2.5 \times 10^{-2} \text{ V}$                       b)  $40 \text{ V}$                       c)  $250 \text{ V}$                       d)  $4 \times 10^{-3} \text{ V}$
138. In the previous question, if the direction of  $i$  is reversed,  $(V_B - V_A)$  will be  
 a)  $20 \text{ V}$                       b)  $15 \text{ V}$                       c)  $10 \text{ V}$                       d)  $5 \text{ V}$
139. The instantaneous voltage through a device of impedance  $20 \Omega$  is  $e = 80 \sin 100 \pi t$ . The effective value of the current is  
 a)  $3 \text{ A}$                       b)  $2.828 \text{ A}$                       c)  $1.732 \text{ A}$                       d)  $4 \text{ A}$
140. In an  $R - C$  circuit while charging, the graph of  $\ln I$  versus time is as shown by the dotted line in the adjoining diagram where  $I$  is the current. When the value of the resistance is doubled, which of the solid curves best represents the variation of  $\ln I$  versus time?

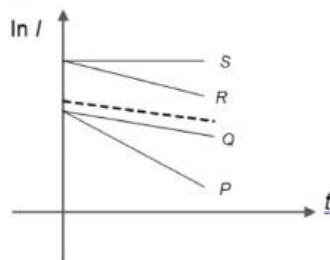

- a)  $P$                       b)  $Q$                       c)  $R$                       d)  $S$
141. The resistance of a coil for dc is in ohms. In ac, the resistance  
 a) Will remain same                      b) Will increase                      c) Will decrease                      d) Will be zero
142. The current  $i$  in the circuit shown here varies with time  $t$  is

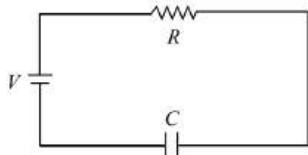

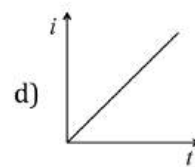
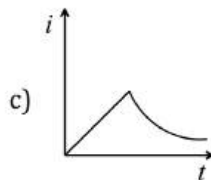
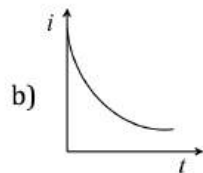
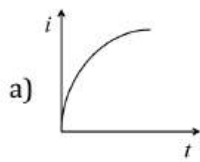

143. A circuit has a resistance of  $11\Omega$ , an inductive reactance of  $25\Omega$  and a capacitive resistance of  $18\Omega$ . It is connected to an ac source of  $260V$  and  $50Hz$ . The current through the circuit (in amperes) is

- a) 11                      b) 15                      c) 18                      d) 20

144. The reading of ammeter in the circuit shown will be

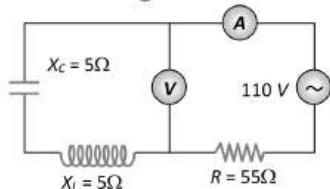

- a)  $2A$                       b)  $2.4A$                       c) Zero                      d)  $1.7A$

145. A step-up transformer is used on a  $120V$  line to provide a potential difference of  $2400V$ . If the primary coil has  $75$  turns, the number of turns in the secondary coil is

- a) 150                      b) 1200                      c) 1500                      d) 1575

146. A coil of inductance  $300mH$  and resistance  $2\Omega$  is connected to a source of voltage  $2V$ . The current reaches half of its steady state value in

- a)  $0.05s$                       b)  $0.1s$                       c)  $0.15s$                       d)  $0.3s$

147. An alternating *e.m.f.* of angular frequency  $\omega$  is applied across an inductance. The instantaneous power developed in the circuit has an angular frequency

- a)  $\omega/4$                       b)  $\omega/2$                       c)  $\omega$                       d)  $2\omega$

148. A  $10\text{ ohm}$  resistance,  $5mH$  coil and  $10\mu F$  capacitor are joined in series. When a suitable frequency alternating current source is joined to this combination, the circuit resonates. If the resistance is halved, the resonance frequency

- a) Is halved                      b) Is doubled                      c) Remains unchanged                      d) In quadrupled

149. There is a  $5\Omega$  resistance in an ac, circuit. Inductance of  $0.1H$  is connected with it in series. If equation of ac *e.m.f.* is  $5\sin 50t$ , then the phase difference between current and *e.m.f.* is

- a)  $\frac{\pi}{2}$                       b)  $\frac{\pi}{6}$                       c)  $\frac{\pi}{4}$                       d) 0

150. In the alternating current shown in the figure, the currents through inductor and capacitor are  $1.2\text{ amp}$  and  $1.0\text{ amp}$  respectively. The current drawn from the generator is

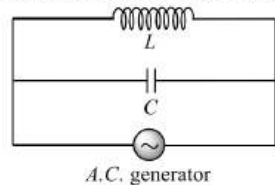

- a)  $0.4\text{ amp}$                       b)  $0.2\text{ amp}$                       c)  $1.0\text{ amp}$                       d)  $1.2\text{ amp}$

151. In a region of uniform magnetic induction  $B = 10^{-2}\text{tesla}$ , a circular coil of radius  $30\text{ cm}$  and resistance  $\pi^2\text{ ohm}$  is rotated about an axis which is perpendicular to the direction of  $B$  and which forms a diameter of the coil. If the rotates at  $200\text{ rpm}$  the amplitude of the alternating current induced in the coil is

- a)  $4\pi^2\text{ mA}$                       b)  $30\text{ mA}$                       c)  $6\text{ mA}$                       d)  $200\text{ mA}$

152. In an  $L - C - R$  circuit, capacitance is changed from  $C$  to  $2C$ . For the resonant frequency to remain unchanged, the inductance should be changed from  $L$  to

- a)  $4L$                       b)  $2L$                       c)  $L/2$                       d)  $L/4$

153. A bulb and a capacitor are in series with an ac source. On increasing frequency how will glow of the bulb change

- a) The glow decreases                      b) The glow increases

c) The glow remain the same

d) The bulb quenches

154. An alternating voltage is represented as  $E = 20 \sin 300t$ . The average value of voltage over one cycle will be

a) Zero

b) 10 volt

c)  $20\sqrt{2}$  volt

d)  $\frac{20}{\sqrt{2}}$  volt

155. The magnet in figure rotates as shown on a pivot through its center. At the instant shown, what are the directions of the induced currents.

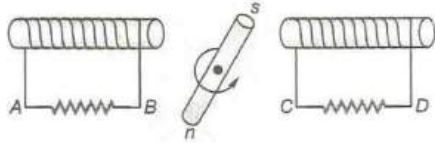

a) A to B and C to D

b) B to A and C to D

c) A to B and D to C

d) B to A and D to C

156. A magnet is suspended lengthwise from a spring and while it oscillates, the magnet moves in and out of the coil C connected to a galvanometer G. Then as the magnet oscillates.

a) G shows no deflection

b) G shows deflection on one side

c) Deflection of G to the left and right has constant amplitude

d) Deflection of G to the left and right has decreasing amplitude

157. Current growth in two  $L - R$  circuits (ii) and (iii) is as shown in figure (i). Let  $L_1, L_2, R_1$  and  $R_2$  be the corresponding values in two circuits. Then

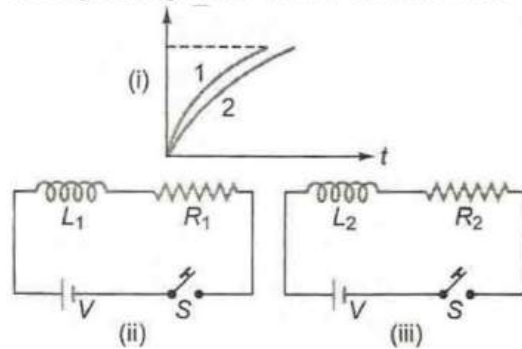

a)  $L_1 > L_2$

b)  $L_1 < L_2$

c)  $R_1 > R_2$

d)  $R_1 = R_2$

158. An electric heater rated 220 V and 550 W is connected to A.C. mains. The current drawn by it is

a) 0.8 A

b) 2.5 A

c) 0.4 A

d) 1.25 A

159. A resistor and a capacitor are connected in series with an AC source. If the potential drop across the capacitor is 5 V and that across resistor is 12 V, then applied voltage is

a) 13 V

b) 17 V

c) 5 V

d) 12 V

160. An inductor of 2 H and a resistance of  $10 \Omega$  are connected in series with a battery of 5 V. the initial rate of change of current is

a)  $0.5 \text{ As}^{-1}$

b)  $2.0 \text{ As}^{-1}$

c)  $2.5 \text{ As}^{-1}$

d)  $0.25 \text{ As}^{-1}$

161. A conducting wire frame is placed in a magnetic field, which is directed into the paper, figure. The magnetic field is increasing at a constant rate. The directions of induced current in wires AB and CD are

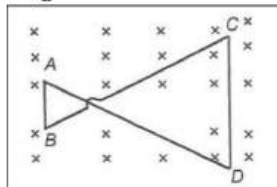

a) A to B and C to D

b) B to A and C to D

c) A to B and D to C

d) B to A and D to C

162. A pure inductive coil of 30 mH is connected to an AC source of 220 V, 50 Hz. The rms current in the coil is

a) 50.35 A

b) 23.4 A

c) 30.5 A

d) 12.3 A



163. In an ac circuit,  $V$  and  $I$  are given by

$V = 100 \sin (100 t)$  volts,  $I = 100 \sin \left(100t + \frac{\pi}{3}\right)$  mA. The power dissipated in circuit is

- a)  $10^4$  watt                      b) 10 watt                      c) 2.5 watt                      d) 5 watt

164. Two concentric and coplanar circular coils have radii  $a$  and  $b$  as shown in figure. Resistance of the inner coil is  $R$ . Current in the other coil is increased from  $0$  to  $i$ , then the total charge circulating the inner coil is

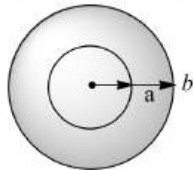

- a)  $\frac{\mu_0 i a b}{2 R}$                       b)  $\frac{\mu_0 i a \pi b^2}{2 a b}$                       c)  $\frac{\mu_0 i b}{2 \pi R}$                       d)  $\frac{\mu_0 i a^2}{2 R b}$

165. A circuit area is  $0.01 \text{ m}^2$  is kept inside a magnetic field which is normal to its plane. The magnetic field changes from  $2 \text{ T}$  to  $1 \text{ T}$  in  $1$  millisecond. If the resistance of the circuit is  $2 \Omega$ . The amount of heat evolved is

- a)  $0.05 \text{ J}$                       b)  $50 \text{ J}$                       c)  $0.50 \text{ J}$                       d)  $500 \text{ J}$

166. In an AC circuit the emf ( $e$ ) and the current ( $i$ ) at any instant are given respectively by

$$e = E_0 \sin \omega t$$

$$i = I_0 \sin(\omega t - \phi)$$

The average power in the circuit over one cycle of AC is

- a)  $\frac{E_0 I_0}{2}$                       b)  $\frac{E_0 I_0}{2} \sin \phi$                       c)  $\frac{E_0 I_0}{2} \cos \phi$                       d)  $E_0 I_0$

167. A copper rod of mass  $m$  slides under gravity on two smooth parallel rails  $l$  distance apart and set at an angle  $\theta$  to the horizontal. At the bottom, the rails are joined by a resistance  $R$ , figure. There is a uniform magnetic field  $B$  perpendicular to the plane of the rails. The terminal velocity of the rod is

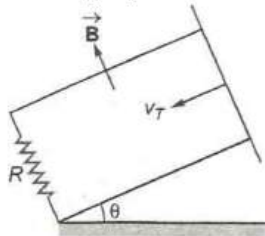

- a)  $\frac{mgR \tan \theta}{B^2 l^2}$                       b)  $\frac{mgR \cot \theta}{B^2 l^2}$                       c)  $\frac{mgR \sin \theta}{B^2 l^2}$                       d)  $\frac{mgR \cos \theta}{B^2 l^2}$

168. Reactance of a capacitor of capacitance  $C \mu\text{F}$  for ac frequency  $\frac{400}{\pi} \text{ Hz}$  is  $25 \Omega$ . The value  $C$  is

- a)  $50 \mu\text{F}$                       b)  $25 \mu\text{F}$                       c)  $100 \mu\text{F}$                       d)  $75 \mu\text{F}$

169. A choke coil has

- a) High inductance and low resistance                      b) Low inductance and high resistance  
c) High inductance and high resistance                      d) Low inductance and low resistance

170. Two coils  $A$  and  $B$  have coefficient of mutual inductance  $M = 2 \text{ H}$ . The magnetic flux passing through coil  $A$  changes by  $4 \text{ Wb}$  in  $10 \text{ s}$  due to change in current in  $B$ . Then

- a) Change in current in  $B$  in this time interval is  $0.5 \text{ A}$                       b) Change in current in  $B$  in this time interval is  $8 \text{ A}$   
c) The change in current in  $B$  in this time interval is  $2$                       d) A change in current of  $1 \text{ A}$  in coil  $A$  will produce a change in flux passing through  $B$  by  $4 \text{ Wb}$

171. In an ac circuit the reactance of a coil is  $\sqrt{3}$  times its resistance, the phase difference between the, voltage across the coil to the current through the coil will be

- a)  $\pi/3$                       b)  $\pi/2$                       c)  $\pi/4$                       d)  $\pi/6$

172. The phase difference between the voltage and the current in an ac circuit is  $\pi/4$ . If the frequency is  $50 \text{ Hz}$  then this phase difference will be equivalent to a time of

- a)  $0.02 \text{ s}$                       b)  $0.25 \text{ s}$                       c)  $2.5 \text{ ms}$                       d)  $25 \text{ ms}$



173. In AC series circuit, the resistance, inductive reactance and capacitive reactance are  $3\Omega$ ,  $10\Omega$  and  $14\Omega$  respectively. The impedance of the circuit is  
 a)  $5\Omega$                       b)  $4\Omega$                       c)  $7\Omega$                       d)  $10\Omega$

174. The voltage across a pure inductor is represented by the following diagram. Which of the following diagrams will represent the current

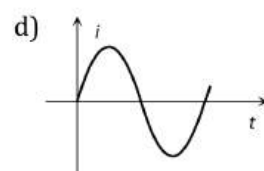
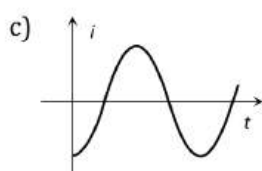
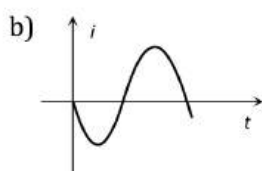
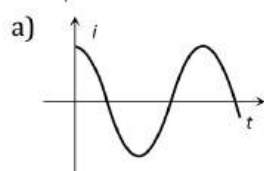
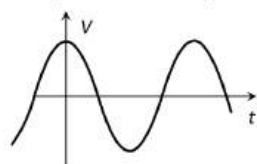

175. Q-factor can be increased by having a coil of

- a) Large inductance, small ohmic resistance
- b) Large inductance, large ohmic resistance
- c) Small inductance, large ohmic resistance
- d) Small inductance, small ohmic resistance

176. The current which does not contribute to the power consumed in an AC circuit is called

- a) non-ideal current
- b) wattles current
- c) convectional current
- d) inductance current

177. In the circuit shown in figure, a conducting wire  $HE$  is moved with a constant speed  $v$  towards left. The complete circuit is placed in a uniform magnetic field  $\vec{B}$  perpendicular to the plane of circuit inwards. The current in  $HKDE$  is

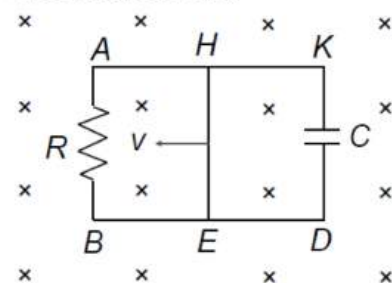

- a) Anti-clock-wise
- b) Clock-wise
- c) Alternating
- d) Zero

178. The current passing through a choke coil of  $5\text{ H}$  is decreasing at the rate of  $2\text{ As}^{-1}$ . The emf developed across the coil is

- a)  $-10\text{ V}$
- b)  $+10\text{ V}$
- c)  $2.5\text{ V}$
- d)  $-2.5\text{ V}$

179. A light bulb is rated  $100\text{ W}$  for a  $220\text{ V}$  supply. The resistance of the bulb and the peak voltage of the source respectively are

- a)  $242\ \Omega$  and  $311\text{ V}$
- b)  $484\ \Omega$  and  $311\text{ V}$
- c)  $484\ \Omega$  and  $440\text{ V}$
- d)  $242\ \Omega$  and  $440\text{ V}$

180. If number of turns in primary and secondary coils is increased to two times each, the mutual inductance

- a) Becomes 4 times
- b) Becomes 2 times
- c) Becomes  $1/4$  times
- d) Remains unchanged

181. An LCR circuit contains  $R = 50\ \Omega$ ,  $L = 1\text{ mH}$  and  $C = 0.1\ \mu\text{F}$ . The impedance of the circuit will be minimum for a frequency of

- a)  $\frac{10^5}{2\pi}\text{ s}^{-1}$
- b)  $\frac{10^6}{2\pi}\text{ s}^{-1}$
- c)  $2\pi \times 10^5\text{ s}^{-1}$
- d)  $2\pi \times 10^6\text{ s}^{-1}$

182. A metal rod of resistance  $20\ \Omega$  is fixed along a diameter of a conducting ring of radius  $0.1\text{ m}$  and lies on  $x - y$  plane. There is a magnetic field  $\vec{B} = (50\text{ T})\hat{k}$ . The ring rotates with an angular velocity  $\omega =$

20  $\text{rads}^{-1}$  about its axis. An external resistance of  $10\ \Omega$  is connected across the centre of the ring and rim. The current through external resistance is

- a)  $\frac{1}{2}$  A                      b)  $\frac{1}{3}$  A                      c)  $\frac{1}{4}$  A                      d) zero

183. A  $12\ \text{ohm}$  resistor and a  $0.21$  henry inductor are connected in series to an ac source operating at  $20\ \text{volts}$ ,  $50$  cycle/second. The phase angle between the current and the source voltage is

- a)  $30^\circ$                       b)  $40^\circ$                       c)  $80^\circ$                       d)  $90^\circ$

184. The ratio of peak value and *r. m. s.* value of an alternating current is

- a) 1                      b)  $\frac{1}{2}$                       c)  $\sqrt{2}$                       d)  $1/\sqrt{2}$

185. In an induction coil, the coefficient of mutual inductance is  $4\text{H}$ . If current of  $5\text{A}$  in the primary coil is cut off in  $1/1500\text{s}$ , the emf at the terminals of the secondary coil will be

- a)  $15\ \text{kV}$                       b)  $60\ \text{kV}$                       c)  $10\ \text{kV}$                       d)  $30\ \text{kV}$

186. The coil of choke in a circuit

- a) Increases the current                      b) Decreases the current  
c) De not change the current                      d) Has high resistance to dc circuit

187. In the *L-C-R* circuit shown, the impedance is

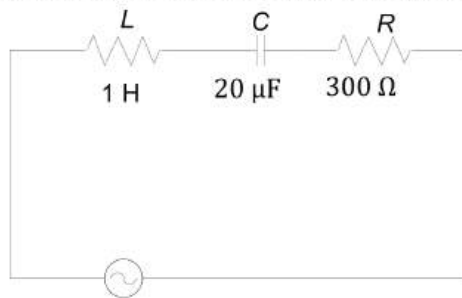

- a)  $500\ \Omega$                       b)  $300\ \Omega$                       c)  $100\ \Omega$                       d)  $200\ \Omega$

188. The frequency of ac mains in India is

- a)  $30\ \text{c/s}$  or  $\text{Hz}$                       b)  $50\ \text{c/s}$  or  $\text{Hz}$                       c)  $60\ \text{c/s}$  or  $\text{Hz}$                       d)  $120\ \text{c/s}$  or  $\text{Hz}$

189. In the circuit shown in the figure, the ac source gives a voltage  $V = 20 \cos(2000t)$ . Neglecting source resistance, the voltmeter and ammeter reading will be

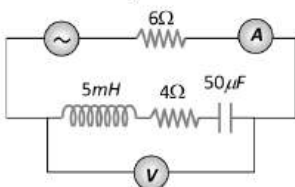

- a)  $0\text{V}$ ,  $0.47\text{A}$                       b)  $1.68\text{V}$ ,  $0.47\text{A}$                       c)  $0\text{V}$ ,  $1.4\ \text{A}$                       d)  $5.6\text{V}$ ,  $1.4\ \text{A}$

190. An *LCR* series ac circuit is at resonance with  $10\ \text{V}$  each across *L*, *C* and *R*. If the resistance is halved, the respective voltage across *L*, *C* and *R* are

- a)  $10\ \text{V}$ ,  $10\ \text{V}$  and  $5\ \text{V}$                       b)  $10\ \text{V}$ ,  $10\ \text{V}$  and  $10\ \text{V}$                       c)  $20\ \text{V}$ ,  $20\ \text{V}$  and  $5\ \text{V}$                       d)  $20\ \text{V}$ ,  $20\ \text{V}$  and  $10\ \text{V}$

191. The readings of ammeter and voltmeter in the following circuit are respectively

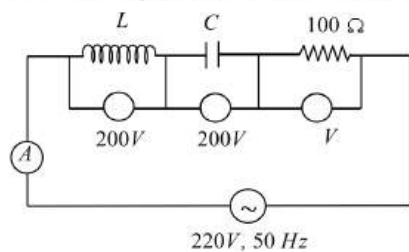

- a)  $2\text{A}$ ,  $200\text{V}$                       b)  $1.5\text{A}$ ,  $100\text{V}$                       c)  $2.7\text{A}$ ,  $220\text{V}$                       d)  $2.2\text{A}$ ,  $220\text{V}$

192. A rectangular loop with a sliding connector of length  $l = 1.0\ \text{m}$  is situated in a uniform magnetic field  $B = 2\text{T}$ . Perpendicular to the plane of loop. Resistance of connector is  $r = 2\ \Omega$ . Two resistance of  $6\ \Omega$  and  $3\ \Omega$

are connected as shown in figure. The external force required to keep the connector moving with a constant velocity  $v = 2 \text{ ms}^{-1}$  is

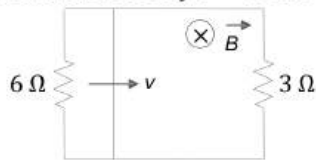

- a) 2 N                      b) 1 N                      c) 4 N                      d) 6 N

193. What is the *r. m. s.* value of an alternating current which when passed through a resistor produces heat which is thrice of that produced by a direct current of 2 amperes in the same resistor

- a) 6 amp                      b) 2 amp                      c) 3.46 amp                      d) 0.66 amp

194. A bulb is connected first with dc and then ac of same voltage it will shine brightly with

- a) AC                      b) DC  
c) Brightness will be in ratio 1/1.4                      d) Equally with both

195. If an alternating voltage is represented as  $E = 141 \sin(628 t)$ , then the rms value of the voltage and the frequency are respectively

- a) 141 V, 628 Hz                      b) 100 V, 50 Hz                      c) 100 V, 100 Hz                      d) 141 V, 100 Hz

196. Some magnetic flux is changed from a coil of resistance  $110 \Omega$ . As a result, an induced current is developed in it, which varies with time as shown in figure. The magnitude of change in flux through the coil in weber is

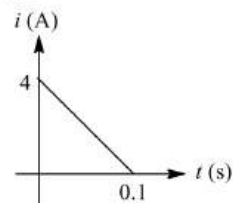

- a) 4                      b) 8                      c) 2                      d) 6

197. Two coils *A* and *B* have 200 and 400 turns respectively. A current of 1 A in coil *A* causes a flux per turn of  $10^{-3} \text{ Wb}$  to link with *A* and a flux per turn of  $0.8 \times 10^{-3} \text{ Wb}$  through *B*. The ratio of mutual inductance of *A* and *B* is

- a) 0.625                      b) 1.25                      c) 1.5                      d) 1.625

198. 220 V, 50 Hz AC is applied to a resistor. The instantaneous value of voltage is

- a)  $220\sqrt{2} \sin 100\pi t$                       b)  $220 \sin 100\pi t$                       c)  $220\sqrt{2} \sin 50\pi t$                       d)  $220 \sin 50\pi t$

199. Two circuits have mutual inductance of 0.09 H. Average emf induced in the secondary by a change of current from 0 to 20 A in 0.006 s in primary will be

- a) 120 V                      b) 200 V                      c) 180 V                      d) 300 V

200. One 10 V, 60 W bulb is to be connected to 100 V line. The required induction coil has self inductance of value ( $f = 50 \text{ Hz}$ )

- a) 0.052 H                      b) 2.42 H                      c) 16.2 mH                      d) 1.62 mH

201. What is self inductance of a coil which produces 5V, when current in it changes from 3 A to 2 A in one millisecond?

- a) 5000 H                      b) 5 mH                      c) 50 H                      d) 5 H

202. The self inductance of a choke coils is 10 mH. When it is connected with a 10V dc source, then the loss of power is 20 watt. When it is connected with 10 volt ac source loss of power is 10 watt. The frequency of ac source will be

- a) 50 Hz                      b) 60 Hz                      c) 80 Hz                      d) 100 Hz

203. In the circuit shown in figure neglecting source resistance, the voltmeter and ammeter readings will be respectively

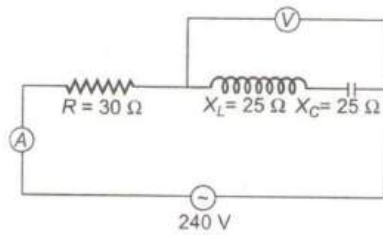

- a) 0 V, 3 A                      b) 150 V, 3 A                      c) 150 V, 6 A                      d) 0 V, 8 A
204. A coil has resistance 30 ohm and inductive reactance 20 Ohm at 50 Hz frequency. If ac source, of 200 volt, 100 Hz, is connected across the coil, the current in the coil will be
- a)  $\frac{20}{\sqrt{13}}A$                       b) 2.0A                      c) 4.0A                      d) 8.0A
205. Eddy current are produced when
- a) A metal is kept in varying magnetic field                      b) A metal is kept in steady magnetic field  
c) A circular coil is placed in a magnetic field                      d) Through a circular coil, current is passed
206. Average power generated in an inductor connected to an AC source is
- a)  $\frac{1}{2}Li^2$                       b)  $Li^2$                       c) Zero                      d) None of these
207. The resonant frequency of a circuit is  $f$ . If the capacitance is made 4 times the initial values, then the resonant frequency will become
- a)  $f/2$                       b)  $2f$                       c)  $f$                       d)  $f/4$
208. Three identical ring move with the same speed on a horizontal surface in a uniform horizontal magnetic field normal to the planes of the rings. The first (A) slips without rolling, the second (B) rolls without slipping, and the third rolls with slipping
- a) The same emf is induced in all the three rings                      b) No emf is induced in any of the rings  
c) In each ring, all points are at the same potential                      d) B develops the maximum induced emf, and A the least.
209. Two coils are at fixed locations. When coil 1 has no current and the current in the coil 2 increases at the rate  $15.0 \text{ As}^{-1}$ , the emf in coil 1 is 25.0 mV. When coil 2 has no current of 3.6 A. The flux linkage in coil 2
- a) 4 mWb                      b) 6 mWb                      c) 10 mWb                      d) 16 mWb
210. In Colpitt oscillator the feedback network consists of
- a) Two inductors and a capacitor                      b) Two capacitors and an inductor  
c) Three pairs of  $R-C$  circuit                      d) Three pairs of  $R-L$  circuit
211. A choke is preferred to a resistance for limiting current in AC circuit because
- a) Choke is cheap                      b) There is no wastage of power  
c) Choke is compact in size                      d) Choke is a good absorber of heat
212. The induced emf of a generator when the flux of poles is doubled and speed is doubled
- a) Becomes half                      b) Remains same  
c) Becomes double                      d) Becomes 4 times
213. In an AC circuit, the instantaneous values of emf and current are  $e = 200 \sin 314t$  volt and  $i = \sin \left( 314t + \frac{\pi}{3} \right)$  amp. The average power consumed in watt is
- a) 200                      b) 100                      c) 50                      d) 25
214. An emf is 15 V is applied in a circuit coil containing 5 H inductance and  $10 \Omega$  resistance. The ratio of currents at time  $t = \infty$  and  $t = 1$  s is
- a)  $\frac{e^{1/2}}{e^{1/2} - 1}$                       b)  $\frac{e^2}{e^2 - 1}$                       c)  $1 - e^{-1}$                       d)  $e^{-1}$
215. For a series  $L - C - R$  circuit, the phase difference between current and voltage at the condition of resonance will be
- a)  $\frac{\pi}{2}$                       b)  $\frac{\pi}{4}$                       c) Zero                      d) Nothing can be said

216. Which of the following components of a  $L - C - R$  circuit, with AC supply, dissipates energy?  
 a)  $L$                                       b)  $R$                                       c)  $C$                                       d) All of these
217. An AC voltage source has an output of  $\Delta V = (200V) \sin 2\pi ft$ . This source is connected to a  $100 \Omega$  resistor. RMS current in the resistance is  
 a) 1.41 A                                      b) 2.41 A                                      c) 3.41 A                                      d) 0.71 A
218. In a pure inductive circuit or In an ac circuit containing inductance only, the current  
 a) Leads the *e.m.f.* by  $90^\circ$                                       b) Lags behind the *e.m.f.* by  $90^\circ$   
 c) Sometimes leads and sometimes lags behind the *e.m.f.*                                      d) Is in phase with the *e.m.f.*
219. An inductance of  $\left(\frac{200}{\pi}\right)$  mH, a capacitance of  $\left(\frac{10^{-3}}{\pi}\right)$  F and a resistance of  $10 \Omega$  are connected in series with an AC source 220 V, 50 Hz. The phase angle of the circuit is  
 a)  $\frac{\pi}{6}$                                       b)  $\frac{\pi}{4}$                                       c)  $\frac{\pi}{2}$                                       d)  $\frac{\pi}{3}$
220. The ratio of turns in primary and secondary coils of a transformer is 1 : 20. The ratio of currents in primary and secondary coils will be  
 a) 1 : 20                                      b) 20 : 1                                      c) 1 : 400                                      d) 400 : 1
221. A group of electric lamps having a total power rating of 1000 watt is supplied by an ac voltage  $E = 200 \sin(310t + 60^\circ)$ . Then the *r. m. s.* value of the circuit current is  
 a) 10 A                                      b)  $10\sqrt{2}$  A                                      c) 20 A                                      d)  $20\sqrt{2}$  A
222. The values of  $L$ ,  $C$  and  $R$  for a circuit are 1H, 9F and  $3\Omega$ . What is the quality factor for the circuit at resonance?  
 a) 1                                      b) 9                                      c)  $\frac{1}{9}$                                       d)  $\frac{1}{3}$
223. In a series resonant circuit, the AC voltage across resistance  $R$ , inductor  $L$  and capacitor  $C$  are 5 V, 10 V and 10 V respectively. The AC voltage applied to the current will be  
 a) 10 V                                      b) 25 V                                      c) 5 V                                      d) 20 V
224. The impedance of a  $R$ - $C$  circuit is  $Z_1$  for frequency  $f$  and  $Z_2$  for frequency  $2f$ . Then,  $\frac{Z_1}{Z_2}$  is  
 a) Between 1 and 2                                      b) 2                                      c) Between  $\frac{1}{2}$  and 1                                      d)  $\frac{1}{2}$
225. A circuit consists of an inductance of 0.5 mH and a capacitor of  $20\mu\text{F}$ . The frequency of the  $L - C$  oscillations is approximately  
 a) 400 Hz                                      b) 88 Hz                                      c) 1600 Hz                                      d) 2400 Hz
226. A coil of  $200\Omega$  resistance and 0.1 H inductance is connected to an ac source of frequency  $200/2\pi$  Hz. Phase angle between potential and current will be  
 a)  $30^\circ$                                       b)  $90^\circ$                                       c)  $45^\circ$                                       d)  $0^\circ$
227. For a coil having  $L = 2$  mH, current flows at the rate of  $10^3 \text{ As}^{-1}$ . The emf induced is  
 a) 2 V                                      b) 1 V                                      c) 4 V                                      d) 3 V
228. In the transmission of a.c. power through transmission lines, when the voltage is stepped up  $n$  times, the power loss in transmission  
 a) Increases  $n$  times                                      b) Decreases  $n$  times  
 c) Increases  $n^2$  times                                      d) Decreases  $n^2$  times
229. The instantaneous values of current and voltage in an ac circuit are  $i = 100 \sin 314 t$  amp and  $e = 200 \sin(314 t + \pi/3)$  V respectively. If the resistance is  $1\Omega$ , then the reactance of the circuit will be  
 a)  $-200\sqrt{3} \Omega$                                       b)  $\sqrt{3} \Omega$                                       c)  $-200\sqrt{3} \Omega$                                       d)  $100\sqrt{3} \Omega$
230. What is the approximate peak value of an alternating current producing four times the heat produced per second by a steady current of 2.0 A in a resistor  
 a) 2.8 A                                      b) 4.0 A                                      c) 5.6 A                                      d) 8.0 A
231. The power is transmitted from a power house on high voltage ac because

- a) Electric current travels faster at higher *volts*  
 b) It is more economical due to less power wastage  
 c) It is difficult to generate power at low voltage  
 d) Changes of stealing transmission lines are minimized
232. Two electric bulbs marked  $25W - 220V$  and  $100W - 220V$  are connected in series to a  $440V$  supply. Which of the bulbs will fuse  
 a) Both                      b)  $100W$                       c)  $25W$                       d) Neither
233. If  $25A$  current is drawn by  $220V$  motor and back emf produced is  $80V$ , the value of armature resistance is  
 a)  $56\Omega$                       b)  $5.6\Omega$                       c)  $0.56\Omega$                       d)  $0.5\Omega$
234. Current in the LCR circuit becomes extremely large when  
 a) Frequency of *AC* supply is increased  
 b) Frequency of *AC* supply is decreased  
 c) Inductive reactance becomes equal to capacitive reactance  
 d) Inductance becomes equal to capacitance
235. The  $i - v$  curve for anti-resonant circuit is

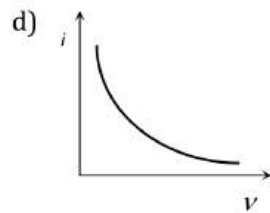
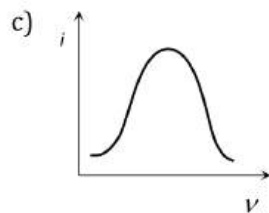
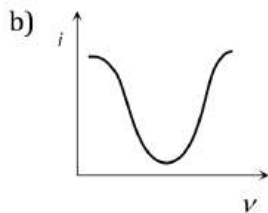
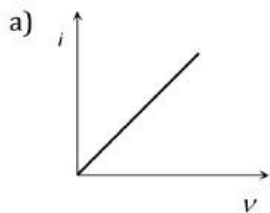

236. The average power dissipated in a pure inductor of inductance  $L$  when an ac current is passing through it, is  
 (Inductance of the coil  $L$  and current  $I$ )  
 a)  $\frac{1}{2}LI^2$                       b)  $\frac{1}{4}LI^2$                       c)  $2LI^2$                       d) Zero
237. An inductor of inductance  $L$  and resistor of resistance  $R$  are joined in series and connected by a source of frequency  $\omega$ . Power dissipated in the circuit is  
 a)  $\frac{(R^2 + \omega^2L^2)}{V}$                       b)  $\frac{V^2R}{(R^2 + \omega^2L^2)}$                       c)  $\frac{V}{(R^2 + \omega^2L^2)}$                       d)  $\frac{\sqrt{R^2 + \omega^2L^2}}{V^2}$
238. The network shown in figure is part of a complete circuit. If a certain instant, the current  $i$  is  $5A$  and is decreasing at a rate  $10^3As^{-1}$ , then  $(V_B - V_A)$  is

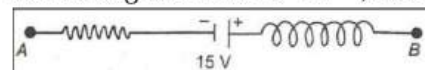

- a)  $20V$                       b)  $15V$                       c)  $10V$                       d)  $5V$
239. For a series  $L-C-R$  circuit at resonance, the statement which is not true is  
 a) Peak energy stored by a capacitor = peak energy stored by an inductor  
 b) Average power = apparent power  
 c) Wattles current is zero  
 d) Power factor is zero
240. In ac circuit of capacitance the current from potential is  
 a) Forward                      b) Backward  
 c) Both are in the same phase                      d) None of these
241. In a  $LCR$  circuit having  $L = 8.0\text{ henry}$ ,  $C = 0.5\mu F$  and  $R = 100\text{ ohm}$  in series. The resonance frequency in per second is  
 a)  $700\text{ radian}$                       b)  $600\text{ Hz}$                       c)  $500\text{ radian}$                       d)  $500\text{ Hz}$
242. Which of the following curves correctly represents the variation of capacitive reactance  $X_C$  with frequency  $f$





- a)  $450 \text{ As}^{-1}$                       b)  $4.5 \text{ As}^{-1}$                       c)  $45 \text{ As}^{-1}$                       d)  $0.45 \text{ As}^{-1}$

255. The voltage of an ac supply varies with time ( $t$ ) as  $V = 120 \sin 100\pi t \cos 100\pi t$ . The maximum voltage and frequency respectively are

- a) 12 volts, 100 Hz                      b)  $\frac{120}{\sqrt{2}}$  volts, 100 Hz                      c) 60 volts, 200 Hz                      d) 60 volts, 100 Hz

256. In an AC circuit the emf( $e$ ) and the current ( $i$ ) at any instant are given respectively by

$$e = E_0 \sin \omega t$$

$$i = I_0 \sin(\omega t - \phi)$$

The average power in the circuit over one cycle of AC is

- a)  $\frac{E_0 I_0}{2}$                       b)  $\frac{E_0 I_0}{2} \sin \phi$                       c)  $\frac{E_0 I_0}{2} \cos \phi$                       d)  $E_0 I_0$

257. From figure shown below a series  $L - C - R$  circuit connected to a variable frequency 200 V source.  $C = 80 \mu\text{F}$  and  $R = 40 \Omega$ . Then the source frequency which drive the circuit at resonance is

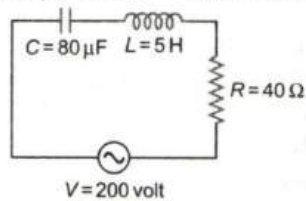

- a) 25 Hz                      b)  $\frac{25}{\pi}$  Hz                      c) 50 Hz                      d)  $\frac{50}{\pi}$  Hz

258. In an ac circuit, the r. m. s. value of current,  $I_{rms}$  is related to the peak current,  $I_0$  by the relation

- a)  $I_{rms} = \frac{1}{\pi} I_0$                       b)  $I_{rms} = \frac{1}{\sqrt{2}} I_0$                       c)  $I_{rms} = \sqrt{2} I_0$                       d)  $I_{rms} = \pi I_0$

259. The time taken by AC of 50 Hz in reaching from zero to the maximum value is

- a)  $50 \times 10^{-3} \text{ s}$                       b)  $5 \times 10^{-3} \text{ s}$                       c)  $1 \times 10^{-3} \text{ s}$                       d)  $2 \times 10^{-3} \text{ s}$

260. In an AC circuit the voltage applied is  $E = E_0 \sin \omega t$ . The resulting current in the circuit is  $I = I_0 \sin(\omega t - \frac{\pi}{2})$ . The power consumption in the circuit is given by

- a)  $P = \frac{E_0 I_0}{\sqrt{2}}$                       b)  $P = \text{zero}$                       c)  $P = \frac{E_0 I_0}{2}$                       d)  $P = \sqrt{2} E_0 I_0$

261. The quality factor of LCR circuit having resistance ( $R$ ) and inductance ( $L$ ) at resonance frequency ( $\omega$ ) is given by

- a)  $\frac{\omega L}{R}$                       b)  $\frac{R}{\omega L}$                       c)  $(\frac{\omega L}{R})^{1/2}$                       d)  $(\frac{\omega L}{R})^2$

262. In a circuit containing an inductance of zero resistance, the e.m.f. of the applied ac voltage leads the current by

- a)  $90^\circ$                       b)  $45^\circ$                       c)  $30^\circ$                       d)  $0^\circ$

263. In an ac circuit, the current is given by  $i = 5 \sin(100 t - \frac{\pi}{2})$  and the ac potential is  $V = 200 \sin(100) \text{ volt}$ .

Then the power consumption is

- a) 20 watts                      b) 40 watts                      c) 1000 watts                      d) 0 watt

264. The graphs given below depict the dependence of two reactive impedances  $X_1$  and  $X_2$  on the frequency of the alternating e.m.f. applied individually to them. We can then say that

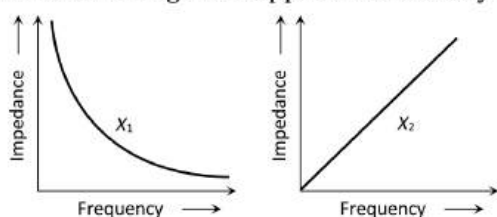

- a)  $X_1$  is an inductor and  $X_2$  is a capacitor                      b)  $X_1$  is a resistor and  $X_2$  is a capacitor  
c)  $X_1$  is a capacitor and  $X_2$  is an inductor                      d)  $X_1$  is an inductor and  $X_2$  is a resistor

265. An alternating current of rms value 10 A is passed through a  $12\ \Omega$  resistor. The maximum potential difference across the resistor is  
 a) 20V                      b) 90V                      c) 169.68 V                      d) None of these
266. A series R-C circuit is connected to AC Voltage source. Consider two cases: (A) when C is without a dielectric medium and (B) when C is filled with dielectric of constant 4. The current  $I_R$  through the resistor and voltage  $V_C$  across the capacitor are compared in the two cases. Which of the following is/are true?  
 a)  $I_R^A > I_R^B$                       b)  $I_R^A < I_R^B$                       c)  $V_C^A > V_C^B$                       d)  $V_C^A < V_C^B$
267. An ac voltage is applied to a resistance R and inductor L in series. If R and the inductive reactance are both equal to  $3\ \Omega$ , the phase difference between the applied voltage and the current in the circuit is  
 a) Zero                      b)  $\pi/6$                       c)  $\pi/4$                       d)  $\pi/2$
268. The phase difference between the alternating current and emf is  $\pi/2$ . Which of the following cannot be the constituent of the circuit?  
 a) C alone                      b) R, L                      c) L, C                      d) L alone
269. Two parallel wires  $A_1L$  and  $B_1M$  placed at a distance  $w$  are connected by a resistor R and placed in a magnetic field B which is perpendicular to the plane containing the wires (see figure). Another wire CD now connects the two wires perpendicularly and made to slide with velocity  $v$  through distance L. The power developed is

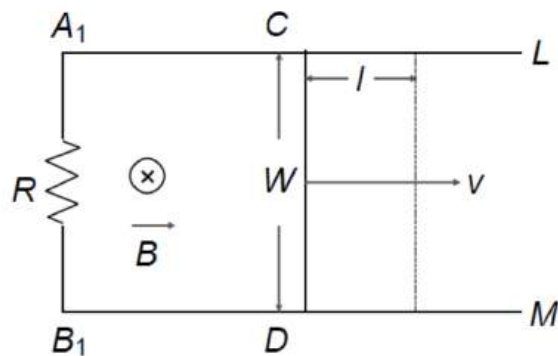

- a)  $B \frac{lv}{R}$                       b)  $\frac{B^2 l^2 v^2}{R}$                       c)  $\frac{Bwv}{R}$                       d)  $\frac{B^2 w^2 v^2}{R}$
270. The diagram shows a capacitor C and a resistor R connected in series to an ac source.  $V_1$  and  $V_2$  are voltmeters and A is an ammeter
- 
- Consider the following statements  
 I. Readings in A are always in phase  
 II. Reading in  $V_1$  is ahead in phase with reading in  $V_2$   
 III. Reading in A and  $V_1$  are always in phase. Which of these statements are/is correct  
 a) I only                      b) II only                      c) I and II only                      d) II and III only
271. The number of turns in the primary coil of a transformer is 200 and the number of turns in secondary coil is 10. If 240 V AC is applied to the primary, the output from secondary will be  
 a) 48 V                      b) 24 V                      c) 12 V                      d) 6 V
272. In a L - R circuit of 3 mH inductance and  $4\ \Omega$  resistance, emf  $E = 4 \cos 1000t$  V is applied. The amplitude of emf is  
 a) 0.8 A                      b)  $\frac{4}{7}$  A                      c) 1.0 A                      d)  $\frac{4}{\sqrt{7}}$  A
273. The resonance frequency of the tank circuit of an oscillator when  $L = \frac{10}{\pi^2}$  mH and  $C = 0.04\ \mu\text{F}$  are connected in parallel is

- a) 250 kHz                      b) 25 kHz                      c) 2.5 kHz                      d) 25 MHz

274. The *r. m. s.* value of potential difference  $V$  shown in the figure is

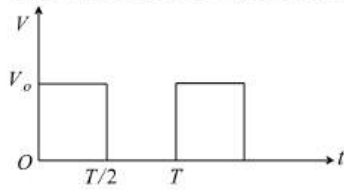

- a)  $V_0/2$                       b)  $V_0/\sqrt{3}$                       c)  $V_0$                       d)  $V_0/\sqrt{2}$
275. A 20 volts ac is applied to a circuit consisting of a resistance and a coil with negligible resistance. If the voltage across the resistance is 12 V, the voltage across the coil is  
a) 16 volts                      b) 10 volts                      c) 8 volts                      d) 6 volts
276. Average power in the  $L$ - $C$ - $R$  circuit depends upon  
a) Current                      b) phase difference only  
c) Emf                      d) Current, emf and phase difference
277. The reactance of a coil when used in the domestic ac power supply (220 volts, 50 cycles per second) is 50 ohms. The inductance of the coil is nearly  
a) 2.2 henry                      b) 0.22 henry                      c) 1.6 henry                      d) 0.16 henry
278. If  $E_0$  is the peak emf,  $I_0$  is the peak current and  $\phi$  is the phase difference between them, then the average power dissipation in the circuit is  
a)  $\frac{1}{2}E_0I_0$                       b)  $\frac{E_0I_0}{\sqrt{2}}$                       c)  $\frac{1}{2}E_0I_0 \sin \phi$                       d)  $\frac{1}{2}E_0I_0 \cos \phi$
279. A coil of resistance  $R$  and inductance  $L$  is connected to a battery of emf  $E$  volt. The final current in the coil is  
a)  $\frac{E}{R}$                       b)  $\frac{E}{L}$                       c)  $\sqrt{\left(\frac{E}{R^2 + L^2}\right)}$                       d)  $\sqrt{\left(\frac{EL}{R^2 + L^2}\right)}$
280. An irregular closed loop carrying a current has a shape such that the entire loop cannot lie in a single plane. If this is placed in a uniform magnetic field, the force acting on the loop  
a) Must be zero                      b) Can never be zero  
c) May be zero                      d) Will be zero only for one particular direction of the magnetic field
281. Mutual inductance of two coils can be increased by  
a) Decreasing the number of turns in the coils                      b) Increasing the number of turns in the coils  
c) Winding the coils on wooden cores                      d) None of the above
282. In a  $L$ - $C$ - $R$  series circuit, the potential difference between the terminals of the inductance is 60 V, between the terminals of the capacitor is 30 V and that across the resistance is 40 V. Then, supply voltage will be equal to  
a) 50 V                      b) 70 V                      c) 130 V                      d) 10 V

283. The value of alternating emf  $E$  in the given circuit will be

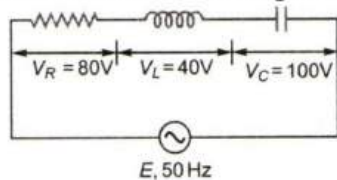

- a) 220 V                      b) 140 V                      c) 100 V                      d) 20 V
284. Choke coil works on the principle of  
a) Transient current                      b) Self induction                      c) Mutual induction                      d) Wattless current
285. In an AC circuit,  $V$  and  $I$  are given by  $V = 150 \sin(150t)$  volt and  $I = 150 \sin\left(150t + \frac{\pi}{3}\right)$  amp.  
The power dissipated in the circuit is  
a) Zero                      b) 5625 W                      c) 150 W                      d) 106 W

286. An  $LCR$  series circuit with  $R = 100\Omega$  is connected to a  $200\text{ V}, 50\text{ Hz}$  a.c. source when only the capacitance is removed, the current leads the voltage by  $60^\circ$ . When only the inductance is removed, the current leads the voltage by  $60^\circ$ . The current in the circuit is

- a)  $2\text{ A}$                       b)  $1\text{ A}$                       c)  $\frac{\sqrt{3}}{2}\text{ A}$                       d)  $\frac{2}{\sqrt{3}}\text{ A}$

287. An electric bulb has a rated power of  $50\text{ W}$  at  $100\text{ V}$ . If it is used on an AC source  $200\text{ V}, 50\text{ Hz}$ , a choke has to be used in series with it. The should have an inductance of

- a)  $0.1\text{ mH}$                       b)  $1\text{ mH}$                       c)  $0.1\text{ H}$                       d)  $1.1\text{ H}$

288. In  $L - C - R$  circuit if resistance increases, quality factor

- a) Increases finitely                      b) Decreases finitely                      c) Remains constant                      d) None of the above

289. In the given circuit diagram the current through the battery and the charge on the capacitor respectively in steady state are

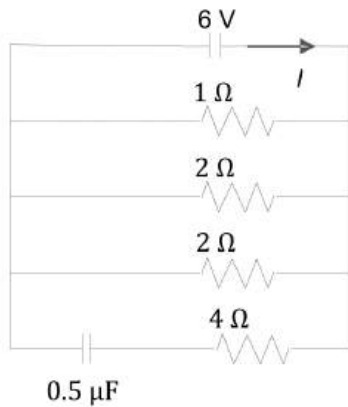

- a)  $1\text{ A}$  and  $3\ \mu\text{C}$                       b)  $17\text{ A}$  and  $0\ \mu\text{C}$                       c)  $\frac{6}{7}\text{ A}$  and  $\frac{12}{7}\ \mu\text{C}$                       d)  $11\text{ A}$  and  $3\ \mu\text{C}$

290. In a series circuit  $C = 2\mu\text{F}, L = 1\text{mH}$  and  $R = 10\Omega$ . When the current in the circuit is maximum, at that time the ratio of the energies stored in the capacitor and the inductor will be

- a)  $1 : 1$                       b)  $1 : 2$                       c)  $2 : 1$                       d)  $1 : 5$

291. The inductive reactance of an inductor of  $\frac{1}{\pi}$  henry at  $50\text{ Hz}$  frequency is

- a)  $\frac{50}{\pi}\text{ ohm}$                       b)  $\frac{\pi}{50}\text{ ohm}$                       c)  $100\text{ ohm}$                       d)  $50\text{ ohm}$

292. In general in an alternating current circuit

- a) The average value of current is zero  
 b) The average value of square of the current is zero  
 c) Average power dissipation is zero  
 d) The phase difference between voltage and current is zero

293. In a series combination  $R = 300\ \Omega, L = 0.9\text{H}, C = 2.0\ \mu\text{F}, \omega = 1000\text{ rads}^{-1}$ , the impedance of the circuit is

- a)  $1300\ \Omega$                       b)  $900\ \Omega$                       c)  $500\ \Omega$                       d)  $400\ \Omega$

294. Three identical coils  $A, B$  and  $C$  are placed with their planes parallel to one another. Coils  $A$  and  $C$  carry currents as shown in figure. Coils  $B$  and  $C$  are fixed in position and coil  $A$  is moved towards  $B$ . Then, current induced in  $B$  is in

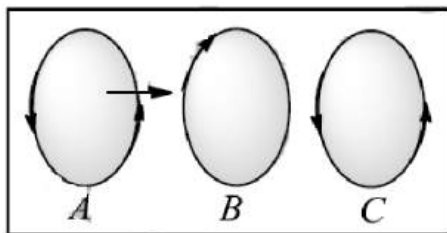

- a) Clock-wise current
- b) Anti-clock-wise current
- c) No current is induced in  $B$
- d) Current is induced only when both coils move

295. Which of the following plots may represent the reactance of a series  $LC$  combination

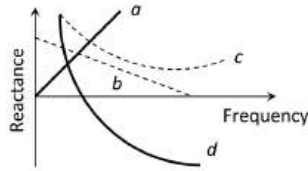

- a)  $a$
- b)  $b$
- c)  $c$
- d)  $d$

296. In an  $L-C-R$  series AC circuit the voltage across  $L$ ,  $C$  and  $R$  is  $10\text{ V}$  each. If the inductor is short circuited, the voltage across the capacitor would become

- a)  $10\text{ V}$
- b)  $\frac{20}{\sqrt{2}}\text{ V}$
- c)  $20\sqrt{2}\text{ V}$
- d)  $\frac{10}{\sqrt{2}}\text{ V}$

297. adsf

- a) 122
- b) 3
- c) 4
- d) 5

298. When current in a coil changes from  $2\text{ A}$  to  $4\text{ A}$  in  $0.05\text{ s}$ , an emf of  $8\text{ V}$  is induced in the coil. Self inductance of the coil is

- a)  $0.1\text{ H}$
- b)  $0.2\text{ H}$
- c)  $0.4\text{ H}$
- d)  $0.8\text{ H}$

299. A telephone wire of length  $200\text{ km}$  has a capacitance of  $0.014\text{ }\mu\text{F}$  per km. If it carries an AC frequency  $5\text{ kHz}$ , what should be the value of an inductor required to be connected in series so that the impedance of the circuit is minimum?

- a)  $0.35\text{ mH}$
- b)  $3.5\text{ mH}$
- c)  $2.5\text{ mH}$
- d) zero

300. The resonance point in  $X_L - f$  and  $X_C - f$  curves is

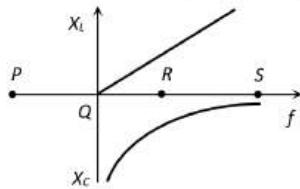

- a)  $P$
- b)  $Q$
- c)  $R$
- d)  $S$

301. The natural frequency of a  $L - C$  circuit is equal to

- a)  $\frac{1}{2\pi}\sqrt{LC}$
- b)  $\frac{1}{2\pi\sqrt{LC}}$
- c)  $\frac{1}{2\pi}\sqrt{\frac{L}{C}}$
- d)  $\frac{1}{2\pi}\sqrt{\frac{C}{L}}$

302. In a purely resistive ac circuit, the current

- a) Lags behind the  $e.m.f.$  in phase
- b) Is in phase with the  $e.m.f.$
- c) Leads the  $e.m.f.$  in phase
- d) Leads the  $e.m.f.$  in half the cycle and lags behind it in the other half

303. In a current carrying long solenoid, the field produced does not depend upon

- a) Number of turns per unit length
- b) Current flowing
- c) Radius of solenoid
- d) All of the above

304. A pure inductor of  $25\text{ mH}$  is connected to a source of  $220\text{ V}$ . Given the frequency of the source as  $50\text{ Hz}$ , the  $rms$  current in the circuit is

- a)  $7\text{ A}$
- b)  $14\text{ A}$
- c)  $28\text{ A}$
- d)  $42\text{ A}$

305. In a choke coil, the reactance  $X_L$  and resistance  $R$  are such that

- a)  $X_L = R$
- b)  $X_L \gg R$
- c)  $X_L \ll R$
- d)  $X_L = \infty$



306. What is the value of inductance  $L$  for which the current is a maximum in a series  $L-C-R$  circuit with  $C = 10\mu\text{F}$  and  $\omega = 1000\text{ s}^{-1}$  ?
- a) 100 mH
  - b) 1 mH
  - c) Cannot be calculated unless  $R$  is known
  - d) 10 mH

307. The peak value of an alternating emf  $E$  given by  $E = E_0 \cos \omega t$  is 10 V and its frequency is 50 Hz. At a time  $t = \frac{1}{100}\text{ s}$ , the instantaneous value of the emf is
- a) 10 V
  - b)  $5\sqrt{3}\text{ V}$
  - c) 5 V
  - d) 1 V

308. Power delivered by the source of the circuit becomes maximum, when
- a)  $\omega L = \omega C$
  - b)  $\omega L = \frac{1}{\omega C}$
  - c)  $\omega L = -\left(\frac{1}{\omega C}\right)^2$
  - d)  $\omega L = \sqrt{\omega C}$

309. An ac source of variable frequency  $f$  is connected to an  $LCR$  series circuit. Which of the graphs in figure represents the variation of current  $I$  in the circuit with frequency  $f$

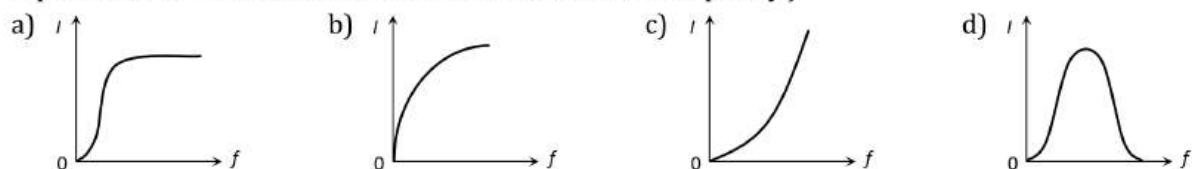

310. In the figure shown, three AC voltmeters are connected. At resonance,

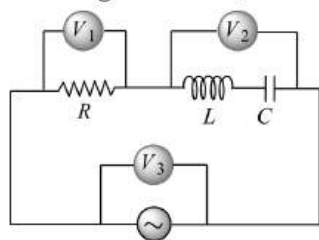

- a)  $V_2 = 0$
  - b)  $V_1 = 0$
  - c)  $V_3 = 0$
  - d)  $V_1 = V_2 \neq 0$
311. In an  $LCR$  circuit  $R = 100\text{ ohm}$ . When capacitance  $C$  is removed, the current lags behind the voltage by  $\pi/3$ . When inductance  $L$  is removed, the current leads the voltage by  $\pi/3$ . The impedance of the circuit is
- a)  $50\text{ ohm}$
  - b)  $100\text{ ohm}$
  - c)  $200\text{ ohm}$
  - d)  $400\text{ ohm}$
312. An alternating current source of frequency  $100\text{ Hz}$  is joined to a combination of a resistance, a capacitance and a coil in series. The potential difference across the coil, the resistance and the capacitor is 46, 8 and 40 volt respectively. The electromotive force of alternating current source in volt is
- a) 94
  - b) 14
  - c) 10
  - d) 76
313. For the series  $L - C - R$  circuit shown in the figure, what is the resonance frequency and the amplitude of the current at the resonating frequency?

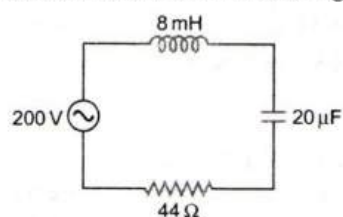

- a)  $2500\text{ rads}^{-1}$  and  $5\sqrt{2}\text{ A}$
  - b)  $2500\text{ rads}^{-1}$  and  $5\text{ A}$
  - c)  $2500\text{ rads}^{-1}$  and  $\frac{5}{\sqrt{2}}\text{ A}$
  - d)  $250\text{ rads}^{-1}$  and  $5\sqrt{2}\text{ A}$
314. The r.m.s. voltage of the wave form shown is

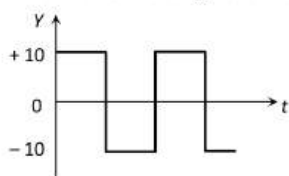

- a) 10 V                      b) 7 V                      c) 6.37 V                      d) None of these
315. In an ac circuit, peak value of voltage is 423 volts. Its effective voltage is  
a) 400 volts                      b) 323 volts                      c) 300 volts                      d) 340 volts
316. An LC circuit contains a 20 mH inductor and a 50  $\mu$ F capacitor with an initial charge of 10 mC. The resistance of the circuit is negligible. Let the instant the circuit is closed be  $t = 0$ . At what time is the energy stored completely magnetic?  
a)  $t = 0$                       b)  $t = 1.57$  ms                      c)  $t = 3.14$  ms                      d)  $t = 6.28$  ms
317. Two inductors of inductance  $L$  each are connected in series with opposite magnetic fluxes. What is the resultant inductance? (Ignore mutual inductance)  
a) Zero                      b)  $L$                       c)  $2L$                       d)  $3L$
318. The current  $i$  passed in any instrument in an AC circuit is  $i = 2 \sin \omega t$  A and potential difference applied is given by  $V = 5 \cos \omega t$  V. Power loss in the instrument is  
a) 10 W                      b) 5 W                      c) Zero W                      d) 20 W
319. The inductance of the oscillatory circuit of the ratio station is 10 mH and its capacitance is 0.25  $\mu$ F. Taking the effect of resistance negligible, wavelength of the broadcasted waves will be (velocity of light =  $3.0 \times 10^8$  ms $^{-1}$ ,  $\pi = 3.14$ )  
a)  $9.42 \times 10^4$  m                      b)  $18.8 \times 10^4$  m                      c)  $4.5 \times 10^4$  m                      d) None of these
320. Two inductors  $L_1$  and  $L_2$  are connected in parallel and a time varying current flows as shown in figure. The ratio of currents  $i_1/i_2$  at any time  $t$  is

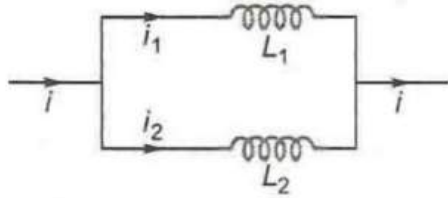

- a)  $L_2/L_1$                       b)  $L_1/L_2$                       c)  $\frac{L_2^2}{(L_1 + L_2)^2}$                       d)  $\frac{L_1^2}{(L_1 + L_2)^2}$
321. In a series  $L - C - R$  circuit, resistance  $R = 10 \Omega$  and the impedance  $Z = 10 \Omega$ . The phase difference between the current and the voltage is  
a)  $0^\circ$                       b)  $30^\circ$                       c)  $45^\circ$                       d)  $60^\circ$
322. In an  $L - C - R$  series AC circuit, the voltage across each of the components,  $L$ ,  $C$  and  $R$  is 50 V. The voltage across the  $L - C$  combination will be  
a) 50 V                      b)  $50\sqrt{2}$  V                      c) 100 V                      d) zero
323. What is the self inductance of an air core solenoid 1 m long, diameter 0.05m, if it has 500 turns? Take  $\pi^2 = 10$ .  
a)  $3.15 \times 10^{-4}$  H                      b)  $4.8 \times 10^{-4}$  H                      c)  $5 \times 10^{-4}$  H                      d)  $6.25 \times 10^{-4}$  H
324. An alternating voltage (in volt) given by  $V = 200\sqrt{2} \sin(100t)$  is connected to  $1\mu$ F capacitor through an AC ammeter. The reading of the ammeter will be  
a) 10 mA                      b) 20 mA                      c) 40 mA                      d) 80 mA
325. The power loss in AC circuit will be minimum when  
a) Resistance is high, inductance is high                      b) Resistance is high, inductance is low  
c) Resistance is low, inductance is low                      d) None of the above
326. An inductance 1 H is connected in series with an AC source of 220 V and 50 Hz. The inductive reactance (in ohm) is  
a)  $2\pi$                       b)  $50\pi$                       c)  $100\pi$                       d)  $1000\pi$
327. A voltage of peak value 283 V and varying frequency is applied to a series  $L - C - R$  combination in which  $R = 3 \Omega$ ,  $L = 25$  mH and  $C = 400\mu$ F. The frequency (in Hz) of the source at which maximum power is dissipated in the above, is  
a) 51.5                      b) 50.7                      c) 51.1                      d) 50.3



328. A fully charged capacitor  $C$  with initial charge  $q_0$  is connected to a coil of self inductance  $L$  at  $t = 0$ . The time at which the energy is stored equally between the electric and the magnetic fields is

- a)  $\frac{\pi}{4}\sqrt{LC}$                       b)  $2\pi\sqrt{LC}$                       c)  $\sqrt{LC}$                       d)  $\pi\sqrt{LC}$

329. An inductor  $L$  and a capacitor  $C$  are connected in the circuit as shown in the figure. The frequency of the power supply is equal to the resonant frequency of the circuit. Which ammeter will read zero ampere

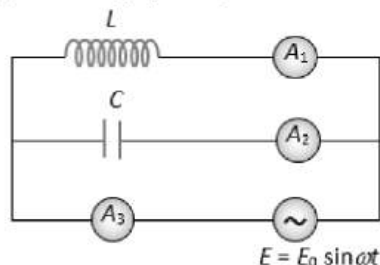

- a)  $A_1$   
 b)  $A_2$   
 c)  $A_3$   
 d) None of these

330. The current ' $i$ ' in an inductance coil varies with time ' $t$ ' according to following graph

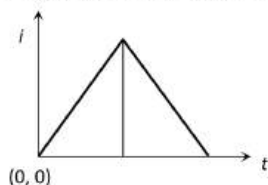

Which of the following plots shows the variation of voltage in the coil

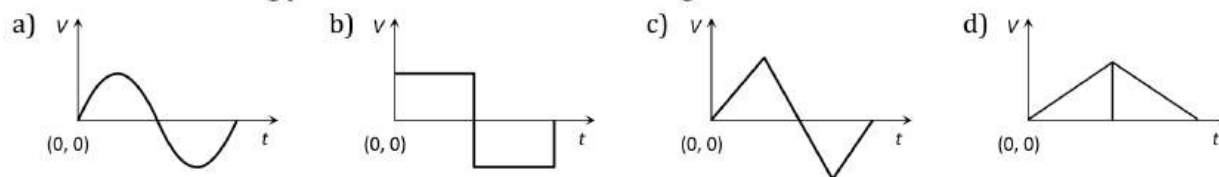

331. What is the average power dissipation in an ideal capacitor in AC circuit?

- a)  $2CV^2$                       b)  $\frac{1}{2}CV^2$                       c) Zero                      d)  $CV^2$

332. Same current is flowing in two alternating circuits. The first circuit contains only inductance and the other contains only a capacitor. If the frequency of the emf of AC is increased, the effect on the value of the current

- a) Increases in the first circuit and decreases in the other  
 b) Increases in both the circuits  
 c) Decreases in both the circuits  
 d) Decreases in the first circuit and increases in the other

333. Consider a short magnetic dipole of magnetic length 10 cm. Its geometric length is

- a) 12 cm                      b) 5                      c) 3                      d) 4

334. In a series resonant  $R-L-C$  circuit, the voltage across  $R$  is 100 V and the value of  $R = 1000 \Omega$ . The capacitance of the capacitor is  $2 \times 10^{-6} \text{ F}$ ; angular frequency of AC is  $200 \text{ rad s}^{-1}$ . Then the potential difference across the inductance coil is

- a) 100 V                      b) 40 V                      c) 250 V                      d) 400 V

335. Find the time required for a 50 Hz alternating current to become its value from zero to the rms value

- a) 10.0 ms                      b) 2.5 ms                      c) 15.0 ms                      d) 5.0 ms

336. Alternating current cannot be measured by DC ammeter because

- a) AC cannot pass through DC ammeter  
 b) AC changes direction



- c) Average value of current for complete cycle is zero  
 d) DC ammeter will get damaged

337. An ac circuit consists of an inductor of inductance  $0.5\text{ H}$  and a capacitor of capacitance  $8\ \mu\text{F}$  in series. The current in the circuit is maximum when the angular frequency of ac source is

- a)  $500\text{ rad/sec}$       b)  $2 \times 10^5\text{ rad/sec}$       c)  $4000\text{ rad/sec}$       d)  $5000\text{ rad/sec}$

338. The armature of a DC motor has a resistance of  $20\ \Omega$ . It draws a current of  $1.5\text{ A}$  when run by  $220\text{ V DC}$ . The value of peak emf induced in it will be

- a)  $150\text{ V}$       b)  $170\text{ V}$       c)  $190\text{ V}$       d)  $180\text{ V}$

339. The maximum value of AC voltage in a circuit is  $707\text{ V}$ . Its rms value is

- a)  $70.7\text{ V}$       b)  $100\text{ V}$       c)  $500\text{ V}$       d)  $707\text{ V}$

340. The impedance of a circuit, when a resistance  $R$  and an inductor of inductance  $L$  are connected in series in an AC circuit of frequency  $f$ , is

- a)  $\sqrt{R + 2\pi^2 f^2 L^2}$       b)  $\sqrt{R + 4\pi^2 f^2 L^2}$       c)  $\sqrt{R^2 + 4\pi^2 f^2 L^2}$       d)  $\sqrt{R^2 + 2\pi^2 f^2 L^2}$

341. A  $4\ \mu\text{F}$  capacitor, a resistance of  $2.5\text{ m}\Omega$  is in series with  $12\text{ V}$  battery. Find the the time after which the potential difference across the capacitor is 3 times the potential difference across the resistor. [Given  $\ln(2)=0.693$ ]

- a)  $13.86\text{ s}$       b)  $6.93\text{ s}$       c)  $7\text{ s}$       d)  $14\text{ s}$

342. An inductor of inductance  $L = 400\text{ mH}$  and resistors of resistances  $R_1 = 4\ \Omega$  and  $R_2 = 2\ \Omega$  are connected to battery of emf  $12\text{ V}$  as shown in the figure. The internal resistance of the battery is negligible. The switch  $S$  is closed at  $t = 0$ . The potential drop across  $L$  as a function of time is

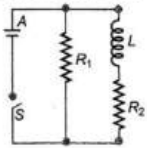

- a)  $6e^{-5t}\text{ V}$       b)  $\frac{12}{t} e^{-3t}\text{ V}$       c)  $6(1 - e^{-t/0.2})\text{ V}$       d)  $12 e^{-5t}\text{ V}$

343. A capacitor  $50\ \mu\text{F}$  is connected to a supply of  $220\text{ V}$  and angular frequency  $50\text{ rad s}^{-1}$ . The value of rms current in the circuit is

- a)  $0.45\text{ A}$       b)  $0.50\text{ A}$       c)  $0.55\text{ A}$       d)  $0.60\text{ A}$

344. In an ideal choke, ratio of its inductance  $L$  to its DC resistance  $R$  is

- a) Infinity      b) Zero      c) Unity      d) hundred

345. In a series  $L - C - R$  circuit the frequency of a  $10\text{ V AC}$  voltage source is adjusted in such a fashion that the reactance of the inductor measures  $15\ \Omega$  and that of the capacitor  $11\ \Omega$ . If  $R = 3\ \Omega$ , the potential difference across the series combination of  $L$  and  $C$  will be

- a)  $8\text{ V}$       b)  $10\text{ V}$       c)  $22\text{ V}$       d)  $52\text{ V}$

346. In the adjoining ac circuit the voltmeter whose reading will be zero at resonance is

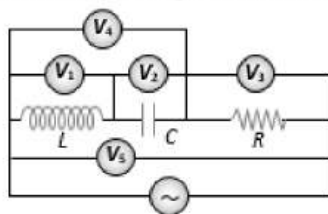

- a)  $V_1$       b)  $V_2$       c)  $V_3$       d)  $V_4$

347. In an ac circuit with voltage  $V$  and current  $I$ , the power dissipated is

- a)  $VI$       b)  $\frac{1}{2}VI$   
 c)  $\frac{1}{\sqrt{2}}VI$       d) Depends on the phases between  $V$  and  $I$

348. Two coils have mutual inductance  $0.005\text{ H}$ . The current changes in the first coil according to equation  $i = i_0 \sin \omega t$  where  $i_0 = 10\text{ A}$  and  $\omega = 100\pi\text{ rads}^{-1}$ . The maximum value of emf in second coil is

- a)  $2\pi$                       b)  $5\pi$                       c)  $\pi$                       d)  $4\pi$

349. A thin semicircular conducting ring of radius  $R$  is falling with its plane vertical in a horizontal magnetic induction  $\vec{B}$ , figure. At the position  $MNQ$ , the speed of the ring is  $v$ . The potential difference developed across the ring is

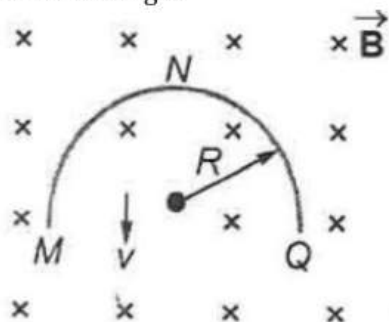

- a) Zero  
 b)  $\frac{1}{2} B v \pi R^2$ , and  $M$  is at a higher potential  
 c)  $\pi R B v$ , and  $Q$  is at a higher potential  
 d)  $2 R B v$ , and  $Q$  is at a higher potential
350. What is the self-inductance of a coil which produces 5 V when the current changes from 3 A to 2 A in one millisecond?  
 a) 5000 H                      b) 5 mH                      c) 50 H                      d) 5 H
351. The number of turns of primary and secondary coils of a transformer is 5 and 10 respectively and mutual inductance of the transformer is 25 H. Now, number of turns in primary and secondary are made 10 and 5 respectively. Mutual inductance of transformer will be  
 a) 25 H                      b) 12.5 H                      c) 50 H                      d) 6.25 H
352. An alternating  $e.m.f.$  is applied to purely capacitive circuit. The phase relation between  $e.m.f.$  and current flowing in the circuit is **or**  
 In a circuit containing capacitance only  
 a)  $e.m.f.$  is ahead of current by  $\pi/2$                       b) Current is ahead of  $e.m.f.$  by  $\pi/2$   
 c) Current lags behind  $e.m.f.$  by  $\pi$                       d) Current is ahead of  $e.m.f.$  by  $\pi$
353. A capacitor and an inductance coil are connected in separate AC circuits with a bulb glowing in both the circuits. The bulb glows more brightly when  
 a) An iron rod is introduced into the inductance coil  
 b) The number of turns in the inductance coil is increased  
 c) Separation between the plates of the capacitor is increased  
 d) A dielectric is introduced into the gap between the plates of the capacitor
354. Which of the following statement is incorrect?  
 a) In a  $L - C - R$  series AC circuit, as the frequency of the source increases, the impedance of the circuit first decreases and then increases  
 b) If the net reactance of an  $L - C - R$  series AC circuit is same as its resistance, then the current lags behind the voltage by  $45^\circ$   
 c) At resonance, the impedance of an AC circuit becomes purely resistive.  
 d) Below resonance, voltage leads the current while above it, current leads the voltage
355. In an AC series circuit, the instantaneous current is maximum when the instantaneous voltage is maximum. The circuit element connected to the source will be  
 a) Pure inductor                      b) Pure capacitor  
 c) Pure resistor                      d) Combination of capacitor and an inductor
356.  $L, C$  and  $R$  represent physical quantities inductance capacitance and resistance respectively. The combination representing dimension of frequency is  
 a)  $LC$                       b)  $(LC)^{-1/2}$                       c)  $\left(\frac{L}{C}\right)^{-1/2}$                       d)  $\frac{C}{L}$

357. A LCR series A. C. circuit is tuned to resonance. The impedance of the circuit is now

- a)  $R$
- b)  $\left[R^2 + \left(\frac{1}{\omega C} - \omega L\right)^2\right]^{1/2}$
- c)  $\left[R^2 + (\omega L)^2 + \left(\frac{1}{\omega C}\right)^2\right]^{1/2}$
- d)  $\left[R^2 + \left(\omega L - \frac{1}{\omega C}\right)^2\right]^{1/2}$

358. In pure inductive circuit, the curves between frequency  $f$  and reciprocal of inductive reactance  $1/X_L$  is

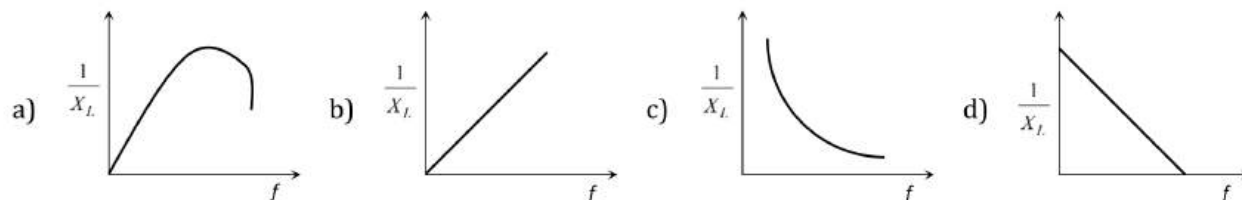

359. In AC circuit in which inductance and capacitance are joined in series. Current is found to be maximum when the value of inductance is 0.5 H and the value of capacitance is 8  $\mu$ F. The angular frequency of applied alternating voltage will be

- a) 4000 Hz
- b) 5000 Hz
- c)  $2 \times 10^5$  Hz
- d) 500 Hz

360. In an AC circuit the instantaneous values of emf and current are

$e = 200 \sin 300 t$  volt  
and  $i = 2 \sin\left(300t + \frac{\pi}{3}\right)$  amp.

The average power consumed in watt is

- a) 200
- b) 100
- c) 50
- d) 400

361. In a series  $L-C-R$  circuit  $R = 200 \Omega$  and the voltage and the frequency of the main supply is 220V and 50 Hz respectively. On taking out the capacitance from the circuit the current lags behind the voltage by  $30^\circ$ . On taking out the inductor from the circuit the current leads the voltage by  $30^\circ$ . The power dissipated in the  $L-C-R$  circuit is

- a) 305 W
- b) 210 W
- c) Zero
- d) 242 W

362. A resistance of 40 ohm and an inductance of 95.5 millihenry are connected in series in a 50 cycles/second ac circuit. The impedance of this combination is very nearly

- a) 30 ohm
- b) 40 ohm
- c) 50 ohm
- d) 60 ohm

363. In the adjoining figure the impedance of the circuit will be

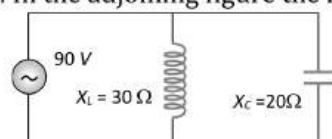

- a) 120 ohm
- b) 50 ohm
- c) 60 ohm
- d) 90 ohm

364. Two coil X and Y are placed in a circuit such that a current changes by 2 A in coil X and magnetic flux change of 0.4 Wb occurs in Y. The value of mutual inductance of the coils is

- a) 0.8 H
- b) 0.2 Wb
- c) 0.2 H
- d) 5 H

365. A 0.7 henry inductor is connected across a 120V – 60 Hz ac source. The current in the inductor will be very nearly

- a) 4.55 amp
- b) 0.355 amp
- c) 0.455 amp
- d) 3.55 amp

366. What will be the self inductance of a coil, to be connected in a series with a resistance of  $\pi\sqrt{3}\Omega$  such that the phase difference between the emf and the current at 50 Hz frequency is  $30^\circ$

- a) 0.5 henry
- b) 0.03 henry
- c) 0.05 henry
- d) 0.01 henry

367. A coil of inductance  $L$  has an inductive reactance of  $X_L$  in an AC circuit in which the effective current is  $I$ . The coil is made from a super-conducting material and has no resistance. The rate at which power is dissipated in the coil is

- a) 0
- b)  $IX_L$
- c)  $I^2X_L$
- d)  $IX_L^2$

368. Time constant of LC circuit is

a)  $\frac{1}{2\pi LC}$

b)  $\frac{1}{2\pi L^2 C^2}$

c)  $\frac{LC}{2\pi}$

d)  $2\pi\sqrt{LC}$

369. In the circuit shown below, the ac source has voltage  $V = 20 \cos(\omega t)$  volts with  $\omega = 2000 \text{ rad/sec}$ . The amplitude of the current will be nearest to

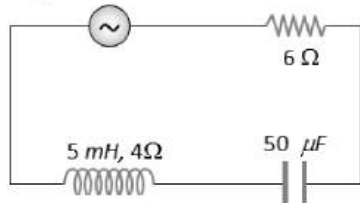

a) 2A

b) 3.3A

c)  $2/\sqrt{5} \text{ A}$

d)  $\sqrt{5} \text{ A}$

370. The following series  $L - C - R$  circuit, when driven by an *e. m. f.* source of angular frequency 70 kiloradians per second, the circuit effectively behaves like

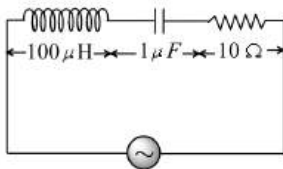

a) Purely resistive circuit

b) Series  $R - L$  circuit

c) Series  $R - C$  circuit

d) Series  $L - C$  circuit with  $R = 0$

371.  $L$ ,  $C$  and  $R$  denote inductance, capacitance and resistance respectively. Pick out the combination which does not have the dimensions of frequency

a)  $\frac{1}{RC}$

b)  $\frac{R}{L}$

c)  $\frac{1}{\sqrt{LC}}$

d)  $\frac{C}{L}$

# ALTERNATING CURRENT

## : ANSWER KEY :

1)	b	2)	a	3)	a	4)	d	161)	d	162)	b	163)	c	164)	d
5)	a	6)	b	7)	a	8)	b	165)	a	166)	c	167)	c	168)	a
9)	b	10)	d	11)	c	12)	d	169)	a	170)	c	171)	a	172)	c
13)	c	14)	a	15)	a	16)	a	173)	a	174)	d	175)	a	176)	b
17)	b	18)	b	19)	c	20)	c	177)	d	178)	b	179)	b	180)	a
21)	b	22)	a	23)	b	24)	d	181)	a	182)	b	183)	c	184)	c
25)	c	26)	b	27)	b	28)	d	185)	d	186)	b	187)	a	188)	b
29)	c	30)	b	31)	a	32)	a	189)	d	190)	d	191)	d	192)	a
33)	a	34)	d	35)	b	36)	b	193)	c	194)	d	195)	c	196)	c
37)	c	38)	d	39)	c	40)	c	197)	a	198)	a	199)	d	200)	a
41)	b	42)	c	43)	b	44)	a	201)	b	202)	c	203)	d	204)	c
45)	d	46)	a	47)	b	48)	d	205)	a	206)	c	207)	a	208)	a
49)	d	50)	b	51)	b	52)	b	209)	b	210)	b	211)	d	212)	d
53)	a	54)	b	55)	c	56)	d	213)	c	214)	b	215)	c	216)	b
57)	a	58)	b	59)	b	60)	b	217)	a	218)	b	219)	b	220)	b
61)	b	62)	a	63)	d	64)	c	221)	b	222)	c	223)	c	224)	b
65)	c	66)	b	67)	b	68)	a	225)	c	226)	c	227)	a	228)	d
69)	d	70)	a	71)	d	72)	c	229)	b	230)	c	231)	b	232)	c
73)	a	74)	d	75)	d	76)	b	233)	b	234)	c	235)	b	236)	d
77)	c	78)	c	79)	a	80)	b	237)	b	238)	b	239)	d	240)	a
81)	d	82)	a	83)	b	84)	a	241)	c	242)	b	243)	b	244)	d
85)	d	86)	d	87)	c	88)	c	245)	c	246)	a	247)	c	248)	a
89)	d	90)	a	91)	c	92)	c	249)	a	250)	b	251)	b	252)	c
93)	b	94)	a	95)	a	96)	b	253)	a	254)	a	255)	d	256)	c
97)	b	98)	c	99)	c	100)	d	257)	b	258)	b	259)	b	260)	b
101)	a	102)	c	103)	b	104)	b	261)	a	262)	a	263)	d	264)	c
105)	c	106)	a	107)	d	108)	c	265)	c	266)	b	267)	c	268)	c
109)	c	110)	d	111)	b	112)	b	269)	d	270)	b	271)	c	272)	a
113)	a	114)	c	115)	b	116)	c	273)	b	274)	d	275)	a	276)	d
117)	b	118)	c	119)	d	120)	d	277)	d	278)	d	279)	a	280)	a
121)	c	122)	b	123)	b	124)	a	281)	b	282)	a	283)	c	284)	b
125)	d	126)	b	127)	a	128)	a	285)	b	286)	a	287)	d	288)	b
129)	a	130)	a	131)	d	132)	d	289)	d	290)	d	291)	c	292)	a
133)	c	134)	a	135)	a	136)	c	293)	c	294)	b	295)	d	296)	d
137)	c	138)	b	139)	b	140)	b	297)	c	298)	b	299)	a	300)	c
141)	b	142)	a	143)	d	144)	c	301)	b	302)	b	303)	c	304)	c
145)	c	146)	b	147)	d	148)	c	305)	b	306)	a	307)	b	308)	b
149)	c	150)	b	151)	c	152)	c	309)	d	310)	a	311)	b	312)	c
153)	b	154)	a	155)	a	156)	d	313)	b	314)	a	315)	c	316)	b
157)	b	158)	b	159)	a	160)	c	317)	c	318)	a	319)	a	320)	a



321) a	322) d	323) d	324) b	349) d	350) b	351) a	352) b
325) c	326) c	327) d	328) a	353) d	354) d	355) c	356) b
329) c	330) b	331) c	332) d	357) a	358) c	359) d	360) b
333) a	334) c	335) d	336) c	361) d	362) c	363) c	364) c
337) a	338) c	339) c	340) c	365) c	366) d	367) a	368) d
341) a	342) d	343) c	344) a	369) a	370) c	371) d	
345) a	346) d	347) d	348) b				



# ALTERNATING CURRENT

## : HINTS AND SOLUTIONS :

1 (b)

$$e = 300\sqrt{2} \sin \omega t$$

$$I_0 = \frac{e_0}{Z} = \frac{300\sqrt{2}}{\sqrt{(30)^2 + (10 - 10)^2}}$$

$$\{\because Z = \sqrt{R^2 + (X_L - X_C)^2}\}$$

$$= \frac{300\sqrt{2}}{30} = 10\sqrt{2} \text{ A}$$

$$\therefore \text{Current } I = \frac{I_0}{\sqrt{2}} = 10 \text{ A}$$

2 (a)

Natural frequency is nothing but resonant frequency.

In this case  $X_L = X_C$

$$\Rightarrow \omega_0 L = \frac{1}{\omega_0 C}$$

$$\Rightarrow \omega_0^2 = \frac{1}{LC}$$

$$\Rightarrow \omega_0 = \frac{1}{\sqrt{LC}}$$

$$\Rightarrow 2\pi f = \frac{1}{\sqrt{LC}}$$

$$\Rightarrow f = \frac{1}{2\pi\sqrt{LC}}$$

3 (a)

At angular frequency  $\omega$ , the current in RC circuit is given by

$$i_{rms} = \frac{V_{rms}}{\sqrt{R^2 + \left(\frac{1}{\omega C}\right)^2}} \quad \dots (i)$$

$$\text{Also } \frac{i_{rms}}{2} = \frac{V_{rms}}{\sqrt{R^2 + \left(\frac{1}{\omega C}\right)^2}} = \frac{V_{rms}}{\sqrt{R^2 + \frac{9}{\omega^2 C^2}}} \quad \dots (ii)$$

From equation (i) and (ii), we get

$$3R^2 = \frac{5}{\omega^2 C^2} \Rightarrow \frac{1}{\omega C} = \sqrt{\frac{3}{5}} \Rightarrow \frac{X_C}{R} = \sqrt{\frac{3}{5}}$$

4 (d)

$$\text{Resistance of coil } (R) = \frac{200}{1} = 200 \Omega$$

$$\text{Current, } I = \frac{200}{\sqrt{R^2 + X_L^2}}$$

$$\text{or } 0.5 = \frac{200}{\sqrt{R^2 + X_L^2}}$$

$$\text{or } R^2 + (2\pi f L)^2 = (400)^2$$

$$\text{or } \left(2\pi f \times \frac{2\sqrt{3}}{\pi}\right)^2 = (400)^2 - (200)^2$$

$$= 120000$$

$$\text{or } 4f\sqrt{3} = 200\sqrt{3}$$

$$\text{or } f = 50 \text{ Hz}$$

5 (a)

$$\cos \phi = \frac{R}{Z}. \text{ In choke coil } \phi = 90^\circ \text{ so } \cos \phi \approx 0$$

6 (b)

$$Q\text{-factor} = \frac{1}{R} \sqrt{\frac{L}{C}} = \frac{1}{6} \sqrt{\frac{1}{17.36 \times 10^{-6}}} = 40$$

7 (a)

$$P = E_{rms} i_{rms} \cos \phi = \frac{E^2 R}{Z^2} = \frac{E^2 R}{\left[R^2 + \left(\omega L - \frac{1}{\omega C}\right)^2\right]}$$

8 (b)

$$R = \frac{P}{i_{rms}^2} = \frac{240}{16} = 15 \Omega; Z = \frac{V}{i} = \frac{100}{4} = 25 \Omega$$

$$\text{Now } X_L = \sqrt{Z^2 - R^2} = \sqrt{(25)^2 - (15)^2} = 20 \Omega$$

$$\therefore 2\pi v L = 20 \Rightarrow L = \frac{20}{2\pi \times 50} = \frac{1}{5\pi} \text{ Hz}$$

9 (b)

$$P = \frac{1}{2} V_0 i_0 \cos \phi \Rightarrow P = P_{peak} \cdot \cos \phi$$

$$\Rightarrow \frac{1}{2} (P_{peak}) = P_{peak} \cos \phi \Rightarrow \cos \phi = \frac{1}{2} \Rightarrow \phi = \frac{\pi}{3}$$

10 (d)

When a ring moves in a magnetic field in a direction perpendicular to its plane, we replace the ring by a diameter ( $2r$ ) perpendicular to the direction of motion. The emf is induced across this diameter. Current flow in the ring will be through the two semicircular portions in parallel. Induced emf =  $B(2r)v$ .

$$\text{Resistance of each half of ring} = R/2$$

As the two halves are in parallel, therefore, equivalent resistance =  $R/4$

$$\therefore \text{Current in the section} = \frac{B(2r)v}{R/4}$$

$$I = \frac{8Brv}{R}$$

13 (c)

$$Z = \sqrt{R^2 + \left(2\pi fL - \frac{1}{2\pi fC}\right)^2}$$

From above equation at  $f = 0, Z = \infty$

When  $f = \frac{1}{2\pi\sqrt{LC}}$  (resonant frequency)  $\Rightarrow Z = R$

For  $f > \frac{1}{2\pi\sqrt{LC}} \Rightarrow Z$  starts increasing

i.e., for frequency  $0 - f_r, Z$  decreases and for  $f_r$  to  $\infty, Z$  increases

This is justified by graph c

14 (a)

$$X_C = \frac{1}{2\pi\nu C} \Rightarrow \frac{1}{1000} = \frac{1}{2\pi \times \nu \times 5 \times 10^{-6}}$$

$$\Rightarrow \nu = \frac{100}{\pi} \text{ MHz}$$

15 (a)

$$i_{rms} = \frac{i_0}{\sqrt{2}} = \frac{5}{\sqrt{2}} = 3.536 \text{ A}$$

16 (a)

$$X_L = \omega L.$$

$$\text{or } L = \frac{X_L}{\omega} = \frac{10}{20} = 0.5 \text{ H}$$

17 (b)

When a circuit contains inductance only, then the current lags behind the voltage by the phase difference of  $\frac{\pi}{2}$  or  $90^\circ$ .

While in a purely capacitive circuit, the current leads the voltage by a phase angle of  $\frac{\pi}{2}$  or  $90^\circ$ .

In a purely resistive circuit current is in phase with the applied voltage.

18 (b)

At  $t = 0$ , inductor behaves like an infinite resistance. So at

$$t = 0, i = \frac{V}{R_2}$$

And at  $t = \infty$ , inductor behaves like a conducting wire,

$$i = \frac{V}{R_{eq}} = \frac{V(R_1 + R_2)}{R_1 R_2}$$

19 (c)

Hot wire ammeter reads rms value of current.

Hence its peak value  $= i_{rms} \times \sqrt{2} = 14.14 \text{ amp}$

20 (c)

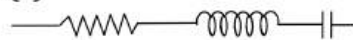

$$\frac{X_C}{R} = \tan \frac{\pi}{3}$$

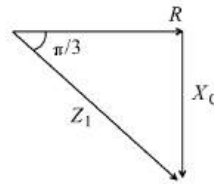

$$X_C = R \tan \frac{\pi}{3} \quad \dots (i)$$

$$\frac{X_L}{R} = \tan \frac{\pi}{3}$$

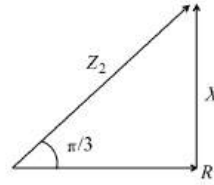

$$X_L = R \tan \frac{\pi}{3} \quad \dots (ii)$$

$$\text{Net impedance } Z = \sqrt{R^2 + (X_L - X_C)^2} = R$$

$$\text{Power factor } \cos \phi = \frac{R}{Z} = 1$$

21 (b)

$$\text{From the relation, } \tan \phi = \frac{\omega L}{R}$$

$$\text{Power factor } \cos \phi = \frac{1}{\sqrt{1 + \tan^2 \phi}}$$

$$= \frac{1}{\sqrt{1 + \left(\frac{\omega L}{R}\right)^2}}$$

$$= \frac{R}{\sqrt{R^2 + \omega^2 L^2}}$$

22 (a)

$$\frac{1}{L_p} = \frac{1}{L} + \frac{1}{L} = \frac{2}{L} \quad \text{or } L_p = \frac{L}{2}$$

Where L is inductance of each part

$$= \frac{1.8 \times 10^{-4}}{2} = 0.9 \times 10^{-4} \text{ H}$$

$$\therefore L_p = \frac{L}{2} = \frac{0.9 \times 10^{-4}}{2} = 0.45 \times 10^{-4} \text{ H}$$

$$\text{Resistance of each part, } r = \frac{6}{2} = 3\Omega$$

$$\text{Now, } \frac{1}{r_p} = \frac{1}{3} + \frac{1}{3} = \frac{2}{3}$$

$$\therefore r_p = 3/2\Omega$$

$$\text{Time constant of circuit} = \frac{L_p}{r_p} = \frac{0.45 \times 10^{-4}}{3/2} = 8A$$

23 (b)

The applied voltage is given by  $V = \sqrt{V_R^2 + V_L^2}$

$$V = \sqrt{(200)^2 + (150)^2} = 250 \text{ volt}$$

24 (d)

The voltage across secondary in zero, as transformer does not work on DC supply.

25 (c)

$$\text{From } e = \frac{L di}{dt}, \text{ when } \frac{di}{dt} = 1, e = L$$

26 (b)

$$\frac{L_2}{L_1} = \frac{N_2^2}{N_1^2}$$



$$\therefore L_2 = L_1 \frac{N_2^2}{N_1^2} = 1.5 \left( \frac{500}{100} \right)^2 = 375 \text{ mH}$$

27 (b)

$$\cos \phi = \frac{R}{Z} = \frac{R}{\sqrt{R^2 + \omega^2 L^2}}$$

$$= \frac{12}{\sqrt{(12)^2 + 4 \times \pi^2 \times (60)^2 \times (0.1)^2}} \Rightarrow \cos \phi = 0.30$$

28 (d)

Magnetic field intensity at a distance  $r$  from the straight wire carrying current is

$$B = \frac{\mu_0 i}{2\pi r}$$

As area of loop,  $A = a^2$

And magnetic flux,  $\phi = BA$

$$\therefore \phi = \frac{\mu_0 i a^2}{2\pi r}$$

The induced emf in the loop is

$$e = \left| \frac{d\phi}{dt} \right| = \left| \frac{d}{dt} \frac{\mu_0 i a^2 v}{2\pi r} \right|$$

$$e = \frac{\mu_0 i a^2}{2\pi r^2} \frac{dr}{dt} = \frac{\mu_0 i a^2 v}{2\pi r^2}$$

Where  $v = \frac{dr}{dt}$  is velocity.

29 (c)

$$\text{Phase difference } \Delta\phi = \phi_2 - \phi_1 = \frac{\pi}{6} - \left( -\frac{\pi}{6} \right) = \frac{\pi}{3}$$

30 (b)

$$\text{As } L = \frac{\mu_0 N^2 A}{l}$$

$$\therefore A \rightarrow \frac{2 \times 2 \times 4}{2} \text{ times} = 8 \text{ times}$$

32 (a)

$$i_p = \frac{n_s}{n_p} i_s = \frac{50}{200} \times 40 = 10 \text{ A}$$

33 (a)

$$\text{Current } i = i_0 \sin(\omega t + \phi)$$

$$i_p = i_0 \sin \omega t \cos \phi + i_0 \cos \omega t \sin \phi$$

$$\text{Thus, } i_0 \cos \phi = 10$$

$$i_0 \sin \phi = 8$$

$$\text{Hence, } \tan \phi = \frac{4}{5}$$

34 (d)

In a purely inductive circuit, current is

$$i = i_0 \sin \left( \omega t - \frac{\pi}{2} \right)$$

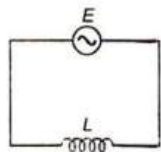

Which shows that the current lags behind the emf by a phase angle of  $\frac{\pi}{2}$  or  $90^\circ$  or the

emf leads the current by a phase angle of  $\frac{\pi}{2}$  or  $90^\circ$ .

35 (b)

$$P = \frac{V_{rms}^2}{R} = \frac{(30)^2}{10} = 90 \text{ W}$$

37 (c)

In series LCR, the impedance of the circuit is given by

$$Z = \sqrt{R^2 + (X_L - X_C)^2}$$

At resonance,  $X_L = X_C$

$$\therefore Z = R$$

At resonance, the phase difference between the current and voltage is  $0^\circ$ . Current is maximum at resonance

39 (c)

$$e = \frac{E_p i_p}{E_s} = \frac{1100 \times 100}{220} = 500 \text{ A} = 0.5 \text{ kA}$$

40 (c)

$$\text{Impedance } Z = \sqrt{R^2 + X^2} = \sqrt{(8)^2 + (6)^2} = 10\Omega$$

41 (b)

$$Z = \sqrt{R^2 + X_L^2}, X_L = \omega L \text{ and } \omega = 2\pi f$$

$$\therefore Z = \sqrt{R^2 + 4\pi^2 f^2 L^2}$$

43 (b)

$$V_{rms} = \frac{V_0}{\sqrt{2}} = \frac{120}{1.414} = 84.8 \text{ V}$$

44 (a)

This is a combined example of growth and decay of current in an  $L-R$  circuit.

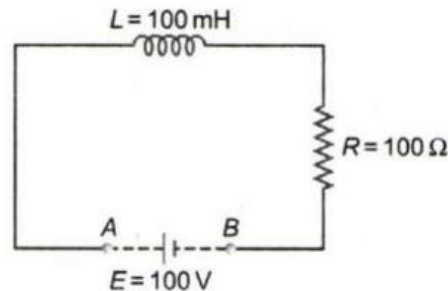

The current through circuit just before shorting the battery,

$$I_0 = \frac{E}{R} = 1 \text{ A}$$

(as inductor would be shorted in steady state)

After this decay of current starts in the circuit according to the equation  $I = I_0 e^{-t/\tau}$

Where  $\tau = L/R$ .

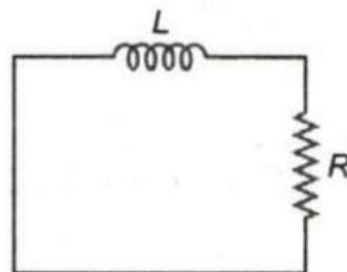

$$I = 1 \times e^{-(1 \times 1 \text{ 0}^{-3}) / (100 \times 1 \text{ 0}^{-3} / 100)} = (1/e) \text{ A}$$

45 (d)

$$\frac{R}{L} = \frac{e/i}{edt/di} = \frac{1}{dt} = \text{frequency.}$$

46 (a)

Phase difference relative to the current

$$\phi = \left(314t - \frac{\pi}{6}\right) - (314t) = -\frac{\pi}{6}$$

47 (b)

At  $t = 0$ , phase of the voltage is zero, while phase of the current is  $-\frac{\pi}{2}$ , i.e., voltage leads by  $\frac{\pi}{2}$

48 (d)

$$\begin{aligned} Z^2 &= R^2 + (2\pi fL)^2 \\ &= (30)^2 + \left(2\pi \times 50 \times \frac{0.4}{\pi}\right)^2 \\ &= (900 + 1600) = 2500 \end{aligned}$$

or  $Z = 50 \Omega$

Also,  $I = \frac{V}{Z} = \frac{200}{50} = 4 \text{ A}$

50 (b)

We know that  $Q$ - factor of series resonant circuit is given as

$$Q = \frac{\omega_r L}{R}$$

Here,  $L = 8.1 \text{ mH}$ ,  $C = 12.5 \mu\text{F}$ ,  $R = 10 \Omega$ ,  $f = 500 \text{ Hz}$

$$\begin{aligned} \therefore Q &= \frac{\omega_r L}{R} = \frac{2\pi fL}{R} \\ &= \frac{2 \times \pi \times 500 \times 8.1 \times 10^{-3}}{10} = \frac{8.1\pi}{10} = 2.5434 \end{aligned}$$

51 (b)

For capacitive circuits  $X_C = \frac{1}{\omega C}$

$$\therefore i = \frac{V}{X_C} = V\omega C \Rightarrow i \propto \omega$$

52 (b)

$$V_0 = \sqrt{2} V_{rms} = 10\sqrt{2}$$

53 (a)

In L-R circuit, the growing current at time  $t$  is

$$\text{given } y \ i = i_0 \left[1 - e^{-\frac{t}{\tau}}\right] \text{ where } i_0 = \frac{E}{R} \text{ and } \tau = \frac{L}{R}$$

$\therefore$  Charge passed through the battery in one time constant is

$$\begin{aligned} q &= \int_0^\tau i dt = \int_0^\tau i_0 (1 - e^{-t/r}) dt \\ q &= i_0 \tau - \left[ \frac{i_0 e^{-t}}{-2/\tau} \right]_0^\tau = i_0 \tau + i_0 \tau [e^{-1} - 1] \\ &= i_0 \tau - i_0 \tau + \frac{i_0 \tau}{e} \\ q &= \frac{i_0 \tau}{e} = \frac{(E/R)(L/R)}{e} = \frac{eL}{eR^2} \end{aligned}$$

54 (b)

$$P_i = 240 \times 0.7 = 168 \text{ W}, P_0 = 140 \text{ W}$$

$$\eta = \frac{P_0}{P_i} \times 100 = \frac{140}{168} \times 100 \approx 80\%$$

55 (c)

Energy stored in a inductor  $L$  carrying

$$\text{Current } i \text{ is } U = \frac{1}{2} L i^2$$

Rate at which energy is stored

$$= \frac{dU}{dt} = \frac{1}{2} L 2i \left(\frac{di}{dt}\right) = Li \left(\frac{di}{dt}\right)$$

$$\text{At } t = 0, i = 0, \therefore \frac{dU}{dt} = 0$$

$$\text{At } t = \infty, i = i_0 \text{ (constant)}, \therefore \frac{di}{dt} = 0$$

56 (d)

$$\text{Required time } t = T/4 = \frac{1}{4 \times 50} = 5 \times 10^{-3} \text{ sec}$$

57 (a)

Maximum voltage is AC circuit

$$V_0 = 282 \text{ V}$$

$$V = \frac{V_0}{\sqrt{2}} = \frac{282}{\sqrt{2}}$$

$$V = \frac{282}{1.41} = \frac{28200}{141}$$

$$V = 200 \text{ V}$$

58 (b)

$$X_C = \frac{1}{2\pi\nu C} = \frac{1}{0} = \infty$$

59 (b)

$$Z = \sqrt{R^2 + X_L^2} = \sqrt{10^2 + (2\pi \times 60 \times 2)^2} = 753.7$$

$$\therefore i = \frac{120}{753.7} = 0.159 \text{ A}$$

60 (b)

An alternating current is one whose magnitude changes continuously with time between zero and a maximum value and whose direction reverses periodically. The relation between frequency ( $f$ ) and time ( $T$ ) is.

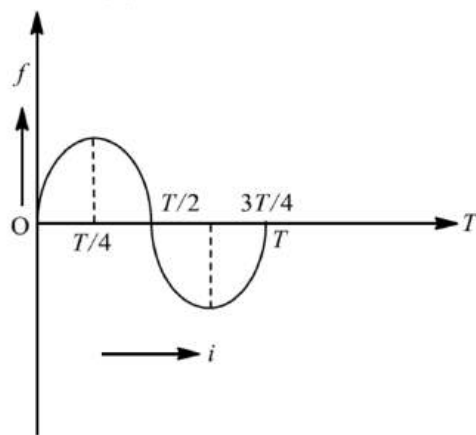

$$T = \frac{1}{f} = \frac{1}{50} = 0.02 \text{ s}$$

As is clear from the figure time taken to reach the maximum value is

$$\frac{T}{4} = \frac{0.02}{4} = 0.005 \text{ s}$$

61 (b)

From  $e = L di/dt \Rightarrow di = \frac{e}{L} = \frac{1}{1} = 1 \text{ As}^{-1}$

62 (a)

After time  $t$ , thickness of liquid will remain  $(\frac{d}{3} - vt)$ .

Now, time constant as function of time

$$\tau_c = CR$$

$$= \frac{\epsilon_0(1) \cdot R}{\left(d - \frac{d}{3} + vt\right) + \frac{d/3 - vt}{2}} \left( \text{Applying } C \right)$$

$$= \frac{\epsilon_0 A}{d - t + \frac{t}{k}}$$

$$= \frac{6\epsilon_0 R}{5d + 3vt}$$

63 (d)

When wire is thick, its resistance reduces. Therefore, Joules' heating loss is reduced.

64 (c)

$$\text{Peak value} = 220\sqrt{2} = 311 \text{ V}$$

65 (c)

$I_L$  lags behind  $I_R$  by a phase of  $\frac{\pi}{2}$ , while  $I_C$  leads by a phase of  $\frac{\pi}{2}$

66 (b)

Time constant of  $R-C$  circuit is  $\tau = RC$   
Here effective resistance of the circuit

$$= \frac{2R \times 3R}{2R + 3R} = \frac{6R}{5}$$

$$\therefore \tau = \frac{6R}{5} \times C = \frac{6RC}{5}$$

67 (b)

$$e = \frac{M di}{dt} = \left( \frac{\mu_0 N_1 N_2 A}{l} \right) \frac{di}{dt}$$

$$= \frac{4\pi \times 10^{-7} \times 2000 \times 300 \times 1.2 \times 10^{-3} (4)}{0.3 \times 0.25}$$

$$= 4.8 \times 10^{-2} \text{ V}$$

68 (a)

$$V = 5 \cos \omega t = 5 \sin \left( \omega t + \frac{\pi}{2} \right) \text{ and } i = 2 \sin \omega t$$

$$\text{Power} = V_{r.m.s.} \times i_{r.m.s.} \times \cos \phi = 0$$

[Since  $\phi = \frac{\pi}{2}$ , therefore  $\cos \phi = \cos \frac{\pi}{2} = 0$ ]

69 (d)

$$i = \frac{V}{Z} = \frac{4}{\sqrt{4^2 + (1000 \times 3 \times 10^{-3})^2}} = 0.8 \text{ A}$$

70 (a)

$$X_L = 31 \Omega, X_C = 25 \Omega, R = 8 \Omega$$

Impedance of series  $LCR$  is

$$Z = \sqrt{R^2 + (X_L - X_C)^2}$$

$$= \sqrt{(8)^2 + (31 - 25)^2} = \sqrt{64 + 36} = 10 \Omega$$

$$\text{Power factor, } \cos \phi = \frac{R}{Z} = \frac{8}{10} = 0.8$$

71 (d)

$$B = \frac{\phi}{A} = \frac{\mu_0 N_1 A i}{LA} = \frac{\mu_0 N^2 i}{L}$$

72 (c)

$$P = E_{r.m.s.} i_{r.m.s.} \cos \phi = \frac{E_0}{\sqrt{2}} \times \frac{i_0}{\sqrt{2}} \times \frac{R}{Z}$$

$$\Rightarrow \frac{E_0}{\sqrt{2}} \times \frac{E_0}{Z\sqrt{2}} \times \frac{R}{Z} \Rightarrow P = \frac{E_0^2 R}{2Z^2}$$

$$\text{Given } X_L = R \text{ so, } Z = \sqrt{2}R \Rightarrow P = \frac{E_0^2}{4R}$$

73 (a)

Since, current lags behind the voltage in phase by a constant angle, then circuit must contain  $R$  and  $L$ .

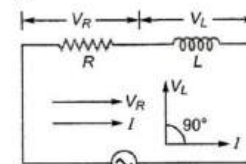

We find that in  $R-L$  circuit, voltage leads the current by a phase angle  $\phi$ , where

$$\tan \phi = \frac{AK}{OA} = \frac{OL}{OA}$$

$$= \frac{V_L}{V_R} = \frac{I_0 X_L}{I_0 R}$$

$$\therefore \tan \phi = \frac{X_L}{R}$$

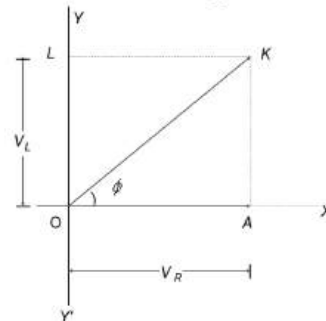

74 (d)

Current will be max at first time when  $100\pi t + \pi/3 = \pi/2 \Rightarrow 100\pi t = \pi/6 \Rightarrow t = 1/600 \text{ s}$

75 (d)

The current will lag behind the voltage when reactance of inductance is more than the reactance of condenser.

$$\text{Thus, } \omega L > \frac{1}{\omega C} \text{ or } \omega > \frac{1}{\sqrt{LC}}$$

or  $n > \frac{1}{2\pi\sqrt{LC}}$  or  $n > n_r$  where  $n_r =$  resonant frequency

76 (b)

$$e = L \frac{di}{dt} \Rightarrow L = \frac{edt}{di} = \frac{8(0.05)}{(4-2)} = 0.2 \text{ H}$$

77 (c)

In  $L - R$  circuit, current at any time  $t$  is given by

$$i = \frac{E}{R} \left( 1 - e^{-\frac{R}{L}t} \right) = \frac{E}{R} - \frac{E}{R} e^{-\frac{R}{L}t}$$

$$\frac{di}{dt} = \frac{E}{R} e^{-\frac{R}{L}t} \left( \frac{R}{L} \right) = \frac{E}{L} e^{-\frac{R}{L}t}$$

$$\text{Induced emf} = L \frac{di}{dt} = E e^{-\frac{R}{L}t}$$

From Eq. (i),  $iR = E - E e^{-\frac{R}{L}t}$

Using Eq. (ii),  $iR = E - e$  or  $e = E - iR$

Therefore, graph between  $e$  and  $i$  is a straight line with negative slope and positive intercept. The choice (c) is correct.

78 (c)

$$U = \frac{1}{2} \frac{q^2}{C} = \frac{1}{2C} (q_0 e^{-t/\tau})^2 = \frac{q_0^2}{2C} e^{-2t/\tau} \quad (\text{where } \tau = CR)$$

$$U = U_i e^{-2t/\tau}$$

$$\frac{1}{2} U_i = U_i e^{-2t_1/\tau}$$

$$\frac{1}{2} = e^{-2t_1/\tau}$$

$\Rightarrow$

$$t_1 = \frac{\tau}{2} \ln 2$$

Now

$$q = q_0 e^{-t/\tau}$$

$$\frac{1}{2} q_0 = q_0 e^{-t_2/\tau}$$

$$t_2 = \tau \ln 4 = 2\tau \ln 2$$

$\therefore$

$$\frac{t_1}{t_2} = \frac{1}{4}$$

79 (a)

At resonance  $LCR$  series circuit behaves as pure resistive circuit. For resistive circuit  $\phi = 0^\circ$

80 (b)

$$Z = \sqrt{R^2 + X^2} = \sqrt{4^2 + 3^2} = 5$$

$$\therefore \cos \phi = \frac{R}{Z} = \frac{3}{5} = 0.6$$

81 (d)

$$i = \frac{220}{\sqrt{(20)^2 + (2 \times \pi \times 50 \times 0.2)^2}} = \frac{220}{66} = 3.33 \text{ A}$$

82 (a)

$$E_s = \frac{n_s}{n_p} E_p = \frac{4200}{2100} \times 120 = 240 \text{ V}$$

$$i_s = \frac{n_s}{n_p} i_p = \frac{2100}{4200} \times 10 = 5 \text{ A}$$

83 (b)

$$i_{r.m.s.} = \frac{i_0}{\sqrt{2}} = \frac{4}{\sqrt{2}} = 2\sqrt{2} \text{ ampere}$$

84 (a)

As the current  $i$  leads the emf  $e$  by  $\frac{\pi}{4}$ , it is an  $R - C$  circuit

$$\tan \phi = \frac{X_C}{R}$$

or  $\tan \frac{\pi}{4} = \frac{1}{\omega C R}$

$$\therefore \omega CR = 1$$

As  $\omega = 100 \text{ rads}^{-1}$

The product of  $C - R$  should be  $\frac{1}{100} \text{ s}^{-1}$ .

85 (d)

Phase angle  $\phi = 90^\circ$ , so power  $P = Vi \cos \phi = 0$

86 (d)

Current lags the voltage if  $\omega L > \frac{1}{\omega C}$

$$f > \frac{1}{2\pi\sqrt{LC}} \Rightarrow f > f_r$$

87 (c)

$$v = \frac{\omega}{2\pi} = \frac{120 \times 7}{2 \times 22} = 19 \text{ Hz}$$

$$V_{r.m.s} = \frac{240}{\sqrt{2}} = 120\sqrt{2} = 170 \text{ V}$$

88 (c)

For an  $R - C$  circuit

$$\text{Applied voltage, } V = \sqrt{V_R^2 + V_C^2}$$

$$\therefore 50 = \sqrt{(40)^2 + V_C^2}$$

$$\Rightarrow V_C = 30 \text{ V}$$

89 (d)

Power factor

$$\begin{aligned} \cos \phi &= \frac{R}{\sqrt{R^2 + \omega^2 L^2}} \\ &= \frac{30}{\sqrt{(30)^2 + (100)^2 \times (400 \times 10^{-3})^2}} \\ &= \frac{30}{\sqrt{900 + 1600}} = \frac{30}{50} = 0.6 \end{aligned}$$

90 (a)

Yes, in  $AC$  if branch  $AB$  has  $R$ ,  $BC$  has a capacitor  $C$ , and  $BD$  has a pure inductance  $L$

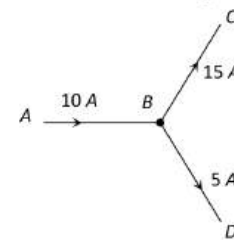

91 (c)

At A :  $X_C > X_L$

At B :  $X_C = X_L$

At C :  $X_C < X_L$

92 (c)

Here: Current in the circuit

$$(i) = 15 \text{ mA} = 15 \times 10^{-3} \text{ A}$$

Resistance  $R = 4000 \text{ Volt}$

Applied voltage in the circuit =  $240 \text{ V}$

At any instant, the  $emf$  of the battery is equal to the sum of potential drop on the resistor and the  $emf$  developed in the induction coil

Hence,  $E = iR + L \frac{di}{dt}$

$$240 = 15 \times 10^{-3} \times 4000 + L \frac{di}{dt}$$

Hence,  $L \frac{di}{dt} = 240 - 60 = 180 \text{ V}$

93 (b)

$L/R$  represents time constant of R-L circuit. Therefore, its dimensions are  $[M^0 L^0 T^1]$ .

94 (a)

This is a parallel circuit, For oscillation, the energy in  $L$  and  $C$  will be alternately maximum

95 (a)

The current in a coil is given by

$$i = i_0 e^{-t/\tau}$$

Now,  $i = \frac{i_0}{\eta}$  in  $t = t_0$

$$\therefore \frac{i_0}{\eta} = i_0 e^{-t_0/\tau}$$

$$e^{-t_0/\tau} = \eta^{-1}$$

Taking log of both sides,

$$-\frac{t_0}{\tau} \log_e e = -1 \log_e \eta$$

$$\frac{t_0}{\tau} = \log_e \eta$$

$$\tau = t_0 / \log_e \eta = t_0 / \ln \eta$$

96 (b)

Since voltage is lagging behind the current, so there must be no inductor in the box

97 (b)

Average power dissipated in an AC circuit

$$P_{av} = V_{rms} I_{rms} \cos \phi \quad \dots(i)$$

Where the term  $\cos \phi$  is known as power factor.

Given,  $V_{rms} = 100 \text{ V}$ ,  $R = 100 \Omega$ ,  $\phi = 30^\circ$

$$\therefore I_{rms} = \frac{V_{rms}}{R} = \frac{100}{100} = 1 \text{ A}$$

Putting the values in Eq. (i), we get

$$P_{av} = 100 \times 1 \times \cos 30^\circ$$

$$= 100 \frac{\sqrt{3}}{2}$$

$$= 50\sqrt{3} = 86.6 \text{ W}$$

98 (c)

$$\tan \phi = \frac{\omega L - \frac{1}{\omega C}}{R}$$

$\phi$  being the angle by which the current leads the voltage.

Given,  $\phi = 45^\circ$

$$\therefore \tan 45^\circ = \frac{\omega L - \frac{1}{\omega C}}{R}$$

$$\Rightarrow 1 = \frac{\omega L - \frac{1}{\omega C}}{R}$$

$$\Rightarrow R = \omega L - \frac{1}{\omega C}$$

$$\Rightarrow C = \frac{1}{\omega(\omega L - R)}$$
$$= \frac{1}{2\pi f(2\pi fL - R)}$$

100 (d)

In an  $L - C - R$  circuit in resonance condition

$$X_L = X_C$$

$$\text{or } X_C - X_L = 0$$

102 (c)

$$\text{As } e = M \frac{di}{dt}$$

$$\therefore 30 \times 10^3 = 3 \times \frac{10}{dt}$$

$$d = \frac{30}{30 \times 10^3} = 10^{-3} \text{ s}$$

103 (b)

Wheatstone bridge is balanced. Current through  $AC$  is zero. Effective resistance  $R$  of bridge is

$$\frac{1}{R} = \frac{1}{6} + \frac{1}{6} = \frac{1}{3}, R = 3\Omega$$

Total resistance =  $1 + 3 = 4\Omega$

Induced emf

$$e = iR = Blv$$

$$\therefore v = \frac{iR}{Bl} = \frac{1 \times 10^{-3} \times 4}{2 \times 0.1}$$

$$= 2 \times 10^{-2} \text{ ms}^{-1}$$

104 (b)

Motional emf across  $PQ$

$$V = Blv = 4(1)(2) = 8 \text{ volt}$$

This is the potential to which the capacitor is charged.

As  $q = CV$

$$\therefore q = (10 \times 10^{-6})8 = 10^{-5} C = 80 \mu C$$

As magnetic force on electron in the conducting rod  $PQ$  is towards  $Q$ , therefore,  $A$  is positively charged and  $B$  is negatively charged

$$\text{ie, } q_A = +80 \mu C \text{ and } q_B = -80 \mu C$$

105 (c)

The DC generator must be mixed wound to withstand the load variation.

106 (a)

For imparting max power

$$X_L = X_C \Rightarrow \omega L = \frac{1}{\omega C}$$

$$C = \frac{1}{\omega^2 L} = \frac{1}{(2\pi f)^2 \times L} = \frac{1}{(100\pi)^2 \times 10}$$
$$= 1 \times 10^{-6} = 1 \mu F$$

108 (c)

$$Z = \sqrt{R^2 + \left(\frac{1}{2\pi\nu C}\right)^2}$$

$$= \sqrt{(3000)^2 + \frac{1}{\left(2\pi \times 50 \times \frac{2.5}{\pi} \times 10^{-6}\right)^2}}$$

$$\Rightarrow Z = \sqrt{(3000)^2 + (4000)^2} = 5 \times 10^3 \Omega$$

So power factor  $\cos \phi = \frac{R}{Z} = \frac{3000}{5 \times 10^3} = 0.6$  and power

$$P = V_{rms} i_{rms} \cos \phi = \frac{V_{rms}^2 \cos \phi}{Z} \Rightarrow P = \frac{(200)^2 \times 0.6}{5 \times 10^3} = 4.8W$$

110 (d)

Rise of current in  $L - R$  circuit is given by

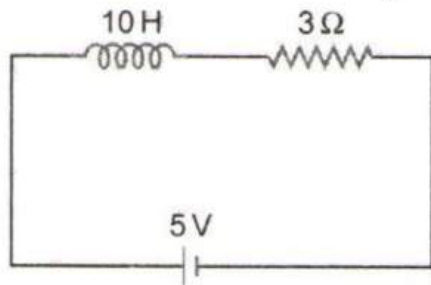

$$I = I_0(1 - e^{-t/\tau})$$

Where,  $I_0 = \frac{E}{R} = \frac{5}{5} = 1 \text{ A}$

Now,  $\tau = \frac{L}{R} = \frac{10}{5} = 2 \text{ s}$

After 2s, i.e., at  $t = 2 \text{ s}$

Rise of current  $I = (1 - e^{-1}) \text{ A}$

111 (b)

As  $e = M di/dt$ ,

$$\therefore M = \frac{edt}{di} = -\frac{15000 \times 0.001}{3} = 5H$$

112 (b)

At resonance,  $LCR$  circuit behaves as purely resistive circuit. For purely resistive circuit power factor = 1

113 (a)

Voltage across the capacitors will increase from 0 to 10 V exponentially. The voltage at time  $t$  will be given by

$$V = 10(1 - e^{-t/\tau_c})$$

Here  $\tau_c = C_{net} R_{net} = (1 \times 10^6)(4 \times 10^{-6}) = 4 \text{ s}$

$$\therefore V = 10(1 - e^{-t/4})$$

Substituting  $V = 4 \text{ volt}$ , we have,

$$4 = 10(1 - e^{-t/4})$$

$$e^{-t/4} = 0.6 = \frac{3}{5}$$

Taking log both sides we have,

$$-\frac{t}{4} = \ln 3 - \ln 5$$

or  $t = 4(\ln 5 - \ln 3) = 2 \text{ s}$ .

114 (c)

From  $L = \frac{\mu_0 N^2 A}{l} = \frac{\mu_0 \mu_r N^2 A}{l}$ ,

When  $\mu = 1000$  and  $N$  becomes  $\frac{1}{10}$

$$\therefore L \text{ becomes } 1000 \times \left(\frac{1}{10}\right)^2 = 10 \text{ times}$$

i.e.,  $L = 10 \times 0.1 = 1H$

115 (b)

From  $R = \frac{E - V}{i}$

$$0.5 = \frac{120 - V}{8}$$

$$V = 116 \text{ V}$$

117 (b)

In non resonant circuits

Impedance  $Z = \frac{1}{\sqrt{\frac{1}{R^2} + \left(\omega C - \frac{1}{\omega L}\right)^2}}$  with rise in

frequency  $Z$  decreases, i.e., current increases so circuit behaves as capacitive circuit

118 (c)

Phase difference in  $R - L$  circuit,

$$\phi = \tan^{-1} \frac{X_L}{R}$$

or  $\tan 45^\circ = \frac{X_L}{R}$

or  $X_L = R$

119 (d)

At resonant frequency current in series  $LCR$  circuit is maximum

120 (d)

Magnetic field at the centre of primary coil  $B = \mu_0 i_1 / 2R_1$ . Considering it to be uniform, magnetic flux passing through secondary coil is

$$\phi = BA = \frac{\mu_0 i_1}{2R_1} (\pi R_2^2)$$

Now,  $M = \frac{\phi_2}{i_1} = \frac{\mu_0 \pi R_2^2}{2R_1}$

$$\therefore M \propto \frac{R_2^2}{R_1}$$

121 (c)

Power remains constant in a ideal step down transformer.

122 (b)

$$V = 50 \times 2 \sin 100\pi t \cos 100\pi t = 50 \sin 200\pi t$$

$$\Rightarrow V_0 = 50 \text{ volts and } \nu = 100 \text{ Hz}$$

123 (b)

Capacitive reactance is given by

$$X_C = \frac{1}{\omega C}$$

Where  $C$  is capacitance and  $\omega$  the angular frequency ( $\omega = 2\pi f$ ).

$$\therefore X_C = \frac{1}{2\pi fC}$$

$$\Rightarrow X_C \propto \frac{1}{f}$$

Hence, when frequency  $f$  increases capacitive reactance decreases.

124 (a)

$$\text{Power factor} = \cos \phi = \frac{R}{Z}$$

$$= \frac{12}{15} = \frac{4}{5} = 0.8$$

125 (d)

$$\text{Given } \omega L = \frac{1}{\omega C} \Rightarrow \omega^2 = \frac{1}{LC}$$

$$\text{Or } \omega = \frac{1}{\sqrt{10^{-3} \times 10 \times 10^{-6}}} = \frac{1}{\sqrt{10^{-8}}} = 10^4$$

$$X_L = \omega L = 10^4 \times 10^{-3} = 10 \Omega$$

126 (b)

$$i_s = \frac{E_s}{Z} = \frac{22}{220} = 0.1 \text{ A}$$

127 (a)

The instantaneous value of voltage is

$$E = 100 \sin(100t) \text{ V} \quad \dots (i)$$

Compare it with  $E = E_0 \sin(\omega t) \text{ V}$

We get

$$E_0 = 100 \text{ V}, \omega = 100 \text{ rads}^{-1}$$

The rms value of voltage is

$$E_{rms} = \frac{E_0}{\sqrt{2}} = \frac{100}{\sqrt{2}} \text{ V} = 70.7 \text{ V}$$

The instantaneous value of current is

$$I = 100 \sin\left(100t + \frac{\pi}{3}\right) \text{ mA}$$

Compare it with

$$I = I_0 \sin(\omega t + \phi)$$

We get

$$I_0 = 100 \text{ mA}, \omega = 100 \text{ rads}^{-1}$$

The rms value of current is

$$I_{rms} = \frac{I_0}{\sqrt{2}} = \frac{100}{\sqrt{2}} \text{ mA} = 70.7 \text{ mA}$$

128 (a)

$$\text{Resistance, } R = \frac{100}{10} = 10 \Omega$$

Inductive reactance,  $X_L = 2\pi fL$

$$\frac{100}{8} = 2\pi \times 50 \times L$$

$$\Rightarrow L = \frac{1}{8\pi} \text{ H}$$

$$X'_L = 2\pi f'L = 2\pi \times 40 \times \frac{1}{8\pi} = 10 \Omega$$

$$\text{Impedance of the circuit is } Z = \sqrt{R^2 + X_L'^2}$$

$$= \sqrt{(10)^2 + (10)^2}$$

$$= 10\sqrt{2} \Omega$$

$$\text{Current in the circuit is } i = \frac{V}{Z} = \frac{150}{10\sqrt{2}} = \frac{15}{\sqrt{2}} \text{ A}$$

129 (a)

$$\therefore (X_C) \gg (X_L)$$

130 (a)

$$i_{rms} = \frac{200}{280} = \frac{5}{7} \text{ A. So } i_0 = i_{rms} \times \sqrt{2} = \frac{5}{7} \times \sqrt{2} \approx 1 \text{ A}$$

132 (d)

In series  $L - R$  circuit, impedance is given by

$$Z = \sqrt{R^2 + X_L^2}$$

Where  $R$  is the resistance and  $X_L$  the inductive reactance.

$$\text{Given, } R = 8 \Omega, X_L = 6 \Omega$$

$$\therefore Z = \sqrt{(8)^2 + (6)^2}$$

$$= \sqrt{64 + 36}$$

$$= \sqrt{100} = 10 \Omega$$

134 (a)

If the current is wattles then power is zero. Hence phase difference  $\phi = 90^\circ$

135 (a)

In  $LCR$  circuit; in the condition of resonance  $X_L = X_C$ , i. e., circuit behaves as resistive circuit. In resistive circuit power factor is maximum

136 (c)

$$I_{av} = \frac{\int_0^{T/2} i dt}{\int_0^{T/2} dt} = \frac{\int_0^{T/2} I_0 \sin(\omega t) dt}{T/2}$$

$$= \frac{2I_0}{T} \left[ \frac{-\cos \omega t}{\omega} \right]_0^{T/2} = \frac{2I_0}{T} \left[ -\frac{\cos\left(\frac{\omega T}{2}\right)}{\omega} + \frac{\cos 0^\circ}{\omega} \right]$$

$$= \frac{2I_0}{\omega T} [-\cos \pi + \cos 0^\circ] = \frac{2I_0}{2\pi} [1 + 1] = \frac{2I_0}{\pi}$$

137 (c)

$$\text{At resonance, } \omega L = \frac{1}{\omega C}$$

Current flowing through the circuit,

$$I = \frac{V_R}{R}$$

$$= \frac{100}{1000} = 0.1 \text{ A}$$

So, voltage across  $L$  is given by

$$V_L = IX_L = I\omega L$$

$$\text{But } \omega L = \frac{1}{\omega C}$$

$$\therefore V_L = \frac{1}{\omega C}$$

$$= \frac{0.1}{200 \times 2 \times 10^{-6}} = 250 \text{ V}$$

138 (b)

When the direction of current is reversed, moving from  $B$  to  $A$ .

$$V_B - V_A = [5 \times 10^{-3}(-10^3) + 15 + 1 \times 5]$$

$$= 15 \text{ volt}$$

139 (b)

The instantaneous voltage through the given device

$$e = 80 \sin 100\pi t$$

Comparing the given instantaneous voltage with standard instantaneous voltage

$$e = e_0 \sin \omega t.$$

We get  $e_0 = 80 \text{ V}$

Where  $e_0$  is the peak value of voltage

Impedance ( $Z$ ) =  $20 \Omega$

$$\begin{aligned} \text{Peak value of current } I_0 &= \frac{e_0}{Z} \\ &= \frac{80}{20} = 4 \text{ A} \end{aligned}$$

Effective value of current (root mean square value of current).

$$\begin{aligned} I_{rms} &= \frac{I_0}{\sqrt{2}} \\ &= \frac{4}{\sqrt{2}} = 2\sqrt{2} = 2.828 \text{ A} \end{aligned}$$

140 (b)

Charging current,  $I = \frac{E}{R} e^{-\frac{t}{RC}}$

Taking log both sides,

$$\text{Log } I = \log \left( \frac{E}{R} \right) - \frac{t}{RC}$$

When  $R$  is doubled, slope of curve increases. Also at  $t = 0$ , the current will be less. Graph  $Q$  represents the best.

141 (b)

The coil has inductance  $L$  besides the resistance  $R$ . Hence for ac it's effective resistance  $\sqrt{R^2 + X_L^2}$  will be larger than it's resistance  $R$  for dc

142 (a)

In  $R$ - $C$  circuit current increases exponentially with time, so correct graph will be (a)

143 (d)

$$\begin{aligned} Z &= \sqrt{R^2 + (X_L - X_C)^2} = \sqrt{(11)^2 + (25 - 18)^2} \\ &= 13 \Omega \end{aligned}$$

$$\text{Current } i = \frac{260}{13} = 20 \text{ A}$$

144 (c)

Given  $X_L = X_C = 5 \Omega$ , this is the condition of resonance. So  $V_L = V_C$ , so net voltage across  $L$  and  $C$  combination will be zero

145 (c)

$$\frac{n_s}{n_p} = \frac{E_s}{E_p} = \frac{2400}{120} = 20$$

$$n_s = 20 n_p = 20 \times 75 = 1500.$$

146 (b)

The current at any instant is given by

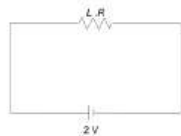

$$I = I_0(1 - e^{-Rt/L})$$

$$\frac{I_0}{2} = I_0(1 - e^{-Rt/L})$$

$$\frac{1}{2} = (1 - e^{-Rt/L})$$

$$e^{-Rt/L} = \frac{1}{2}$$

$$\frac{Rt}{L} = 1 \text{ n } 2$$

$$\begin{aligned} \therefore t &= \frac{L}{2} 1 \text{ n } 2 = \frac{300 \times 10^{-3}}{2} \times 0.693 \\ &= 150 \times 0.693 \times 10^{-3} \\ &= 0.10395 \text{ s} = 0.1 \text{ s} \end{aligned}$$

147 (d)

The instantaneous values of emf and current in inductive circuit are given by  $E = E_0 \sin \omega t$  and  $i = i_0 \sin \left( \omega t - \frac{\pi}{2} \right)$  respectively

$$\text{So, } P_{\text{inst}} = Ei = E_0 \sin \omega t \times i_0 \sin \left( \omega t - \frac{\pi}{2} \right)$$

$$= E_0 i_0 \sin \omega t \left( \sin \omega t \cos \frac{\pi}{2} - \cos \omega t \sin \frac{\pi}{2} \right)$$

$$= E_0 i_0 \sin \omega t \cos \omega t$$

$$= \frac{1}{2} E_0 i_0 \sin 2\omega t \quad (\sin 2\omega t = 2 \sin \omega t \cos \omega t)$$

Hence, angular frequency of instantaneous power is  $2\omega$

148 (c)

Resonance frequency =  $\frac{1}{2\pi\sqrt{LC}}$  does not depend on resistance

149 (c)

$$\begin{aligned} \cos \phi &= \frac{R}{Z} = \frac{R}{\sqrt{R^2 + \omega^2 L^2}} = \frac{5}{\sqrt{25 + (50)^2 \times (0.1)^2}} \\ &= \frac{5}{\sqrt{25 + 25}} = \frac{1}{\sqrt{2}} \Rightarrow \phi = \pi/4 \end{aligned}$$

151 (c)

$$\begin{aligned} \text{Amplitude of } ac &= i_0 = \frac{V_0}{R} = \frac{\omega NBA}{R} = \frac{(2\pi\nu)NB(\pi r^2)}{R} \\ \Rightarrow i_0 &= \frac{2\pi \times \frac{200}{60} \times 1 \times 10^{-2} \times \pi \times (0.3)^2}{\pi^2} = 6 \text{ mA} \end{aligned}$$

152 (c)

In the condition of resonance

$$X_L = X_C$$

$$\text{or } \omega L = \frac{1}{\omega C} \quad \dots(i)$$

Since, resonant frequency remains unchanged,

$$\text{So, } \sqrt{LC} = \text{constant}$$

$$\text{or } LC = \text{constant}$$

$$\therefore L_1 C_1 = L_2 C_2$$

$$\Rightarrow L \times C = L_2 \times 2C$$

$$\Rightarrow L_2 = \frac{L}{2}$$

153 (b)



This is because, when frequency  $\nu$  is increased, the capacitive reactance  $X_C = \frac{1}{2\pi\nu C}$  decreases and hence the current through the bulb increases

155 (a)

In the rotation of magnet,  $N$  pole moves closer to coil  $CD$  and  $S$  pole moves closer to coil  $AB$ . As per Lenz's law,  $N$  pole should develop at the end corresponding to  $C$ . Induced current flows from  $C$  to  $D$ . Again  $S$  pole should develop at the end corresponding to  $B$ . Therefore, induced current in the coil flows from  $A$  to  $B$ .

156 (d)

As a given pole ( $N$  or  $S$ ) of suspended magnet goes into the coil and comes out of its, current is induced in the coil in two opposite directions. Therefore, galvanometer deflection goes to left and right both. As amplitude of oscillation of magnet goes on decreasing, so does the amplitude of deflection.

157 (b)

As is for Fig. (i), steady state current for  $t = \infty$  both the circuits is same. Therefore,

$$\frac{V}{R_1} = \frac{V}{R_2}$$

$$\text{Or } R_1 = R_2$$

Again, from the same figure, we observe that

$$\tau_1 < \tau_2 \quad \therefore \frac{L_1}{R_1} < \frac{L_2}{R_2}$$

As  $R_1 = R_2$ , therefore,  $L_1 < L_2$ .

158 (b)

$$P = VI$$

$$I = \frac{550}{220} = 2.5 \text{ A}$$

159 (a)

Let the applied voltage be  $V$  volt.

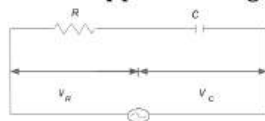

$$\text{Here, } V_R = 12 \text{ V, } V_C = 5 \text{ V}$$

$$\begin{aligned} \therefore V &= \sqrt{V_R^2 + V_C^2} = \sqrt{(12)^2 + (5)^2} \\ &= \sqrt{144 + 25} = \sqrt{169} = 13 \text{ V} \end{aligned}$$

160 (c)

$$i = i_0 \left( 1 - e^{-\frac{Rt}{L}} \right)$$

$$\Rightarrow \frac{di}{dt} = \frac{d}{dt} i_0 - \frac{d}{dt} \left( i_0 e^{-\frac{Rt}{L}} \right) = 0 + \frac{i_0 R}{L} e^{-\frac{Rt}{L}}$$

Initially,  $t = 0$

$$\Rightarrow \frac{di}{dt} = \frac{i_0 \times R}{L} = \frac{E}{L} = \frac{5}{2} = 2.5 \text{ As}^{-1}$$

161 (d)

As the magnetic field directed into the paper is increasing at a constant rate, therefore, induced current should produce a magnetic field directed out of the paper. Thus current in both the loops must be anti-clock-wise.

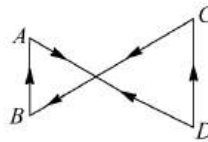

As area of loop on right side is more, therefore, induced emf of right side of loop will be more compared to the emf induced on the left-side of the loop

$$\left[ \therefore e = -\frac{d\phi}{dt} = -A \frac{dB}{dt} \right]$$

162 (b)

$$\text{Given, } L = 30 \text{ mH}$$

$$V_{rms} = 220 \text{ V}$$

$$f = 50 \text{ Hz}$$

$$\text{Now, } X_L = \omega L = 2\pi fL$$

$$= 2 \times 3.14 \times 50 \times 30 \times 10^{-3}$$

$$= 9.42 \Omega$$

The rms current in the coil is

$$i_{rms} = \frac{V_{rms}}{X_L} = \frac{220 \text{ V}}{9.42 \Omega} = 23.4 \text{ A}$$

163 (c)

$$P = V_{r.m.s.} \times i_{r.m.s.} \times \cos \phi$$

$$= \frac{100}{\sqrt{2}} \times \frac{100 \times 10^{-3}}{\sqrt{2}} \times \cos \frac{\pi}{3}$$

$$= \frac{10^4 \times 10^{-3}}{2} \times \frac{1}{2} = \frac{10}{4} = 2.5 \text{ watt}$$

164 (d)

Initial flux linked with inner coil when  $i = 0$  is zero. Final flux linked with inner coil when  $i = i$  is

$$i \text{ is } \left( \frac{\mu_0 i}{2\pi b} \right) \pi a^2$$

$$\therefore \text{Change in flux, } d\phi = \left( \frac{\mu_0 i}{2\pi b} \right) \pi a^2$$

$$\text{As } dq = \frac{d\phi}{R}$$

$\therefore$  Total charge circulating the inner coil is

$$= \left( \frac{\mu_0 i}{2\pi b} \right) \frac{\pi a^2}{R} = \frac{\mu_0 i a^2}{2 R b}$$

165 (a)

Induced emf produced in coil

$$e = \frac{-d\phi}{dt} = \frac{-d}{dt} (BA)$$

$$\therefore |e| = A \frac{dB}{dt} = 0.01 \times \frac{1}{1 \times 10^{-3}}$$

$$|e| = 10 \text{ V}$$

Current produced in coil,

$$i = \frac{|e|}{R} = \frac{10}{2} = 5 \text{ A}$$

$$\text{Heat evolved} = i^2 R t$$

$$= (5)^2 \times (2) \times 1 \times 10^{-3} = 0.05 \text{ J}$$

166 (c)

Power = Rate of work done in one complete cycle.

$$\text{or } P_{av} = \frac{W}{T}$$

$$\text{or } P_{av} = \frac{(E_0 I_0 \cos \phi) T / 2}{T}$$

$$\text{or } P_{av} = \frac{E_0 I_0 \cos \phi}{2}$$

Where  $\cos \phi$  is called the power factor of an AC circuit.

167 (c)

Terminal velocity of the rod is attained when magnetic force on the rod ( $Bil$ ) balances the component of weight of the rod ( $mg \sin \theta$ ), figure.

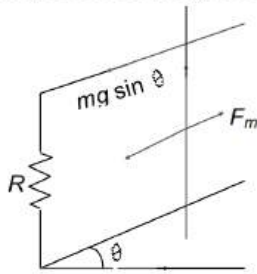

$$\text{ie, } Bil = mg \sin \theta$$

$$B \left( \frac{e}{R} \right) l = mg \sin \theta$$

$$\frac{Bl}{R} (e) = mg \sin \theta$$

$$\frac{Bl}{R} (Blv_r) = mg \sin \theta$$

$$r_T = \frac{mg R \sin \theta}{B^2 l^2}$$

168 (a)

$$X_C = \frac{1}{2\pi\nu C} \Rightarrow C = \frac{1}{2\pi\nu X_C} = \frac{1}{2 \times \pi \times \frac{400}{\pi} \times 25}$$

$$= 50 \mu F$$

170 (c)

Here,  $M = 2\text{H}$ ,  $d\phi = 4 \text{ Wb}$ ,  $dt = 10 \text{ s}$

$$\text{As } \phi = M i$$

$$d\phi = M di$$

$$\text{Or } di = \frac{d\phi}{M} = \frac{4}{2} = 2 \text{ A}$$

$$\text{Also, } d\phi = M (di) = 2(1)$$

$$= 2 \text{ Wb}$$

171 (a)

$$\tan \phi = \frac{X_L}{R} = \frac{\sqrt{3} R}{R} = \sqrt{3} \Rightarrow \phi = 60^\circ = \pi/3$$

172 (c)

$$\text{Time difference} = \frac{T}{2\pi} \times \phi = \frac{(1/50)}{2\pi} \times \frac{\pi}{4} = \frac{1}{400} \text{ s} = 2.5 \text{ m-s}$$

173 (a)

Here, Resistance,  $R = 3\Omega$

Inductive reactance,  $X_L = 10\Omega$

Capacitive reactance,  $X_C = 14\Omega$

The impedance of the series LCR circuit is

$$Z = \sqrt{R^2 + (X_C + X_L)^2} = \sqrt{(3)^2 + (14 - 10)^2}$$

$$Z = 5\Omega$$

174 (d)

In purely inductive circuit voltage leads the current by  $90^\circ$

175 (a)

$$Q \text{ factor is given by } \frac{1}{R} \sqrt{\frac{L}{C}}$$

So, for large quality factor the inductance should be large and resistance and capacitance must be small

176 (b)

$$\text{As, power factor} = \frac{\text{true power}}{\text{apparent power}}$$

$$= \cos \phi$$

$$= \frac{R}{\sqrt{R^2 + (X_L - X_C)^2}}$$

$$\therefore \text{ power factor} = \cos \phi = \frac{R}{Z}$$

In a non-inductive circuit,  $X_L = X_C$

$$\therefore \text{ Power factor} = \cos \phi = \frac{R}{\sqrt{R^2}} = \frac{R}{R} = 1$$

$$\therefore \phi = 0^\circ$$

This is the maximum value of power factor. In a pure inductor or an ideal capacitor

$$\phi = 90^\circ$$

$$\therefore \text{ Power factor} = \cos \phi = \cos 90^\circ = 0$$

Average power consumed in a pure inductor or ideal capacitor

$$P = E_v \cdot I_v \cos 90^\circ = \text{zero}$$

Therefore, current through pure  $L$  or pure  $C$ , which consumes no power for its maintenance in the circuit is called ideal current or wattless current.

177 (d)

Potential difference across the capacitor = emf induced across  $HE = Blv$  which is constant.

Therefore, charge stored in the capacitor is constant. Hence current in the circuit  $HKDE$  is zero.

178 (b)

$$e = -L di/dt = -5 \times (-2) = +10 \text{ V}$$

179 (b)

$$\text{Resistance of a bulb} = \frac{(\text{Rated voltage})^2}{\text{Rated power}}$$

$$= \frac{(220)^2}{100} = 484 \Omega$$

Peak voltage of the source,  $V_0 = 220\sqrt{2} \text{ V} = 311 \text{ V}$

180 (a)

As  $M = \frac{\mu_0 N_1 N_2 A}{l}$ , therefore,  $M$  becomes 4 times

181 (a)

Impedance of  $LCR$  circuit will be minimum at resonant frequency so

$$V_0 = \frac{1}{2\pi\sqrt{LC}} = \frac{1}{2\pi\sqrt{1 \times 10^{-3} \times 0.1 \times 10^{-6}}} = \frac{10^5}{2\pi} \text{ Hz}$$

182 (b)

Here, resistance of rod =  $2\Omega$ ,  $r = 0.1 \text{ m}$ ,  $B = 50 \text{ T}$ , along  $z$  - axis  $\omega = 20 \text{ rads}^{-1}$ .

Potential difference between centre of the ring and the rim is

$$V = \frac{1}{2} B \omega r^2 = \frac{1}{2} \times 50 \times 20 \times (0.1)^2 = 5 \text{ V}$$

The equivalent circuit of the arrangement is shown in figure

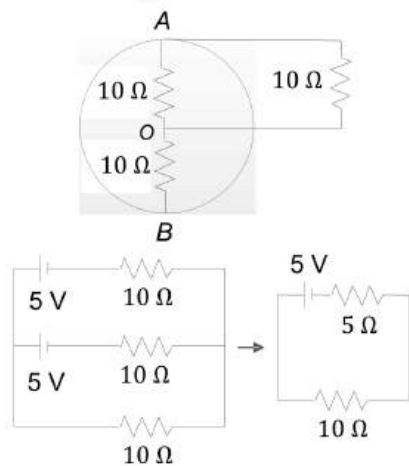

Current through external resistance,

$$i = \frac{E}{R+r} = \frac{5}{10+2} = \frac{5}{12} \text{ A}$$

183 (c)

$$\tan \phi = \frac{\omega L}{R} = \frac{2\pi \times 50 \times 0.21}{12} = 5.5 \Rightarrow \phi = 80^\circ$$

185 (d)

$$e = L di/dt = 4 \times \frac{5}{1/1500} = 30000 \text{ V} = 30 \text{ kV}$$

187 (a)

$$X_L = 2\pi fL = 2\pi \left(\frac{50}{\pi}\right) \times 1 = 100\Omega$$

$$X_C = \frac{1}{2\pi fC}$$

$$= \frac{1}{2\pi \left(\frac{50}{\pi}\right) \times 20 \times 10^{-6}} = 500 \Omega$$

$$\text{Impedance } Z = \sqrt{(R)^2 + (X_C - X_L)^2} = \sqrt{(300)^2 + (400)^2}$$

$$= 500 \Omega$$

189 (d)

$$Z = \sqrt{(R)^2 + (X_L - X_C)^2};$$

$$R = 10\Omega, X_L = \omega L = 2000 \times 5 \times 10^{-3} = 10\Omega$$

$$X_C = \frac{1}{\omega C} = \frac{1}{2000 \times 50 \times 10^{-6}} = 10\Omega, \text{ i.e., } Z = 10\Omega$$

$$\text{Maximum current } i_0 = \frac{V_0}{Z} = \frac{20}{10} = 2 \text{ A}$$

$$\text{Hence } i_{\text{rms}} = \frac{2}{\sqrt{2}} = 1.4 \text{ A and } V_{\text{rms}} = 4 \times 1.41 = 5.64 \text{ V}$$

191 (d)

$$V = \sqrt{V_R^2 + (V_L - V_C)^2}$$

$$\because V_R = V \quad \because V_L = V_C$$

$$\therefore \text{Reading of voltmeter} = 220 \text{ V}$$

$$\text{Reading of ammeter } I_{\text{rms}} = \frac{E_{\text{rms}}}{Z}$$

$$= \frac{220}{100} = 2.2 \text{ A}$$

192 (a)

Motion emf induced in the connector

$$e = Blv = 2(1)(2) = 4 \text{ V}$$

This acts as a cell of emf 4 V and internal resistance  $2\Omega$ .  $6\Omega$  and  $3\Omega$  resistors are in parallel.

$$\therefore \frac{1}{R_p} = \frac{1}{6} + \frac{1}{3} = \frac{1+2}{6} = \frac{3}{6} = \frac{1}{2}$$

$$R_p = 2 \Omega$$

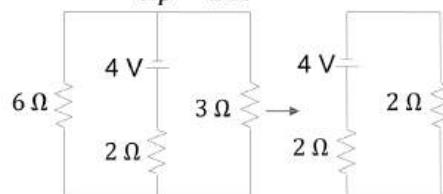

$\therefore$  Current through the connector ( $i$ )

$$= \frac{E}{R_p+r} = \frac{4}{2+2} = 1 \text{ A.}$$

Magnetic force on the connector

$$= Bil = (1)(1) = 2 \text{ N}$$

Therefore, to keep the connector moving with a constant velocity, a force of 2 N has to be applied to the right side.

193 (c)

Heat produced by ac = 3  $\times$  Heat produced by dc

$$\therefore i_{\text{rms}}^2 R t = 3 \times i^2 R t \Rightarrow i_{\text{rms}}^2 = 3 \times i^2$$

$$\Rightarrow i_{\text{rms}} = 2\sqrt{3} = 3.46 \text{ A}$$

194 (d)

Brightness  $\propto P_{\text{consumed}} \propto \frac{1}{R}$ . For bulb,  $R_{\text{ac}} = R_{\text{dc}}$ ,

so brightness will be equal in both the cases

195 (c)

$$E = 141 \sin 628t$$

$$\therefore E_{rms} = \frac{E_0}{\sqrt{2}} = \frac{141}{1.41} = 100 \text{ V}$$

and  $v = \frac{\omega}{2\pi} = \frac{628}{2 \times 3.14} = 100 \text{ Hz}$

196 (c)

Here,  $R = 10 \Omega$ . As is known,  
 $|dq| = \frac{d\phi}{R} = |i dt| = \text{area under } i - t \text{ graphs.}$   
 $\therefore \frac{d\phi}{R} = \frac{(4)(0.1)}{2} = 0.2$   
 $d\phi = 0.2 R = 0.2 \times 10 = 2 \text{ Wb}$

197 (a)

From  $\phi = Mi$   
 $\frac{M_1}{M_2} = \frac{\phi_1}{\phi_2} = \frac{10^{-3} \times 200}{0.8 \times 10^{-3} \times 400} = \frac{10}{16} = 0.625$

198 (a)

Here,  $V_{rms} = 220 \text{ V}$ ,  $v = 50 \text{ Hz}$   
 Peak value of voltage  $V_0 = \sqrt{2} V_{rms} = 220\sqrt{2} \text{ V}$   
 $\therefore$  The instantaneous value of voltage is  
 $V = V_0 \sin 2\pi vt = 220\sqrt{2} \sin 2\pi \times 50t$   
 $= 220\sqrt{2} \sin 100\pi t$

199 (d)

$$e = \frac{M di}{dt} = 0.09 \times \frac{20}{0.006} = 300 \text{ V}$$

200 (a)

Current through the bulb  $i = \frac{P}{V} = \frac{60}{10} = 6 \text{ A}$

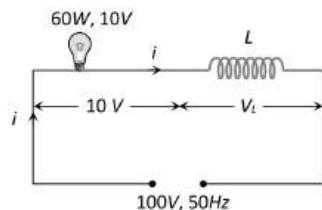

$$V = \sqrt{V_R^2 + V_L^2}$$

$$(100)^2 = (10)^2 + V_L^2$$

$$\Rightarrow V_L = 99.5 \text{ Volt}$$

Also  $V_L = iX_L = i \times (2\pi vL)$   
 $\Rightarrow 99.5 = 6 \times 2 \times 3.14 \times 50 \times L$   
 $\Rightarrow L = 0.052 \text{ H}$

201 (b)

$$L = ? e = 5 \text{ V}, \frac{di}{dt} = \frac{(2-3)}{10^{-3}} = -10^3 \text{ As}^{-1}$$

As  $e = -L \frac{di}{dt}$   
 $\therefore 5 = -L(-10^3), L = \frac{5}{10^3} \text{ H} = 5 \text{ mH}$

202 (c)

With dc:  $P = \frac{V^2}{R} \Rightarrow R = \frac{(10)^2}{20} = 5 \Omega$ ;  
 With ac:  $P = \frac{V_{rms}^2}{Z^2} \Rightarrow Z^2 = \frac{(10)^2 \times 5}{10} = 50 \Omega^2$

Also  $Z^2 = R^2 + 4\pi^2 v^2 L^2$   
 $\Rightarrow 50 = (5)^2 + 4(3.14)^2 v^2 (10 \times 10^{-3})^2 \Rightarrow v = 80 \text{ Hz}$

203 (d)

The voltage  $V_L$  and  $V_C$  are equal and opposite so, voltmeter reading will be zero.

Also,  $R = 30 \Omega, X_L = X_C = 25 \Omega$

So,  $i = \frac{V}{\sqrt{R^2 + (X_L - X_C)^2}} = \frac{V}{R} = \frac{240}{30} = 8 \text{ A}$

204 (c)

If  $\omega = 50 \times 2\pi$  then  $\omega L = 20 \Omega$

If  $\omega' = 100 \times 2\pi$  then  $\omega' L = 40 \Omega$

$$I = \frac{200}{Z} = \frac{200}{\sqrt{R^2 + (\omega' L)^2}} = \frac{200}{\sqrt{(30)^2 + (40)^2}}$$

$$I = 4 \text{ A}$$

205 (a)

Eddy currents are produced when a metal is kept in a varying magnetic field.

206 (c)

After the current in the inductor reaches its maximum value  $I_0$ , it falls from  $I_0$  to zero. The energy  $\frac{1}{2} LI_0^2$  supplied by the source during build up of current is returned back to the source during the fall of current.

Thus, net power supplied by the source in a complete cycle is zero.

207 (a)

$$f = \frac{1}{2\pi\sqrt{LC}} \Rightarrow f \propto \frac{1}{\sqrt{C}}$$

208 (a)

The same emf is induced in all the three rings because emf is only due to linear motion and does not depend on spin.

209 (b)

As  $e = M \frac{di}{dt}$   
 $\therefore M = \frac{e}{di/dt} = \frac{25 \times 10^{-3}}{15.0} = 1.67 \times 10^{-3} \text{ H}$

As  $\phi = Mi$

$$\therefore \phi = 1.67 \times 10^{-3} \times 3.6 = 6 \times 10^{-3} \text{ Wb} = 6 \text{ mWb}$$

210 (b)

In Colpitt oscillator two capacitors are placed across a common inductor and the centre of the two capacitors is tapped.

211 (d)

In an AC circuit, the coil of high inductance and negligible resistance used to control current, is

called the choke coil. The power factor of such a coil is given by

$$\cos \phi = \frac{R}{\sqrt{R^2 + \omega^2 L^2}}$$

$$\approx \frac{R}{\omega L} \quad (\text{as } R \ll \omega L)$$

As  $R \ll \omega L$ ,  $\cos \phi$  is very small. Thus, the power absorbed by the coil is very small. The only loss of energy is due to hysteresis in the iron core, which is much less than the loss of energy in the resistance that can also reduce the current if placed instead of the choke coil.

212 (d)

$e_0 = NAB\omega$ . When  $B$  and  $\omega$  are doubled,  $e_0$  becomes 4 times.

213 (c)

$$V_{\text{rms}} = \frac{200}{\sqrt{2}}, I_{\text{rms}} = \frac{1}{\sqrt{2}}$$

$$\therefore P = V_{\text{rms}} I_{\text{rms}} \cos \phi = \frac{200}{\sqrt{2}} \frac{1}{\sqrt{2}} \cos \frac{\pi}{3} = 50 \text{ W}$$

214 (b)

Here,  $i = i_0$  at  $t = \infty$ . Let  $i$  be the current at  $t = 1$  s

$$\text{From } i = i_0 \left(1 - e^{-\frac{R}{L}t}\right)$$

$$= i_0 \left(1 - e^{-\frac{10}{5} \times 1}\right) = i_0 \left(1 - \frac{1}{e^2}\right)$$

$$\therefore \frac{i_0}{i} = \frac{e^2}{e^2 - 1}$$

215 (c)

In a series  $L - C - R$  circuit, potential difference leads the current by an angle  $\phi$  (let).

$$\phi = \tan^{-1} \left( \frac{X_L - X_C}{R} \right)$$

or 
$$\phi = \tan^{-1} \left( \frac{\omega L - \frac{1}{\omega C}}{R} \right)$$

At resonance,  $X_L = X_C$ , i.e.,  $\omega L = \frac{1}{\omega C}$

Hence, 
$$\phi = \tan^{-1}(0) = 0$$

Therefore, phase difference between current and voltage at resonance is zero.

216 (b)

The average power output of the emf source is

$$P = \frac{1}{2} |V_0| |I_0| \cos \theta$$

Since,

$$V_0 = I_0 R$$

$$\therefore P = \frac{1}{2} R |I_0|^2$$

It is clear that only the resistor dissipates energy in the circuit. The inductor and capacitor both store energy but they eventually return it to the circuit without dissipation.

217 (a)

$$I_0 = \frac{V_0}{R} = \frac{200}{100} = 2 \text{ A}$$

$$I_{\text{rms}} = \frac{I_0}{\sqrt{2}} = 1.414 \text{ A}$$

219 (b)

The phase angle ( $\theta$ ) between  $I$  and  $V$  is given by

$$\tan \theta = \frac{X_L - X_C}{R} \quad \dots(i)$$

Where,  $X_L = 2\pi fL$

$$= 2\pi \times 50 \times \left[ \frac{200}{\pi} \times 10^{-3} \right]$$

$$= 20 \Omega$$

$$X_L = \frac{1}{2\pi fC}$$

$$= \frac{1 \times \pi}{2\pi \times 50 \times 10^{-3}}$$

$$= 10 \Omega$$

and  $R = 10 \Omega$

Substituting values of  $X_L$ ,  $X_C$  and  $R$  in eq.(i), we get

$$\tan \theta = \frac{20 - 10}{10} = 1$$

$$\Rightarrow \tan \theta = \tan \frac{\pi}{4}$$

$$\therefore \theta = \frac{\pi}{4}$$

The phase angle of the circuit is  $\frac{\pi}{4}$ .

220 (b)

$$\frac{n_p}{n_s} = \frac{1}{20}$$

As 
$$\frac{i_p}{i_s} = \frac{n_s}{n_p}$$

$$\therefore \frac{i_p}{i_s} = 20 : 1$$

221 (b)

$$P = \frac{1}{2} V_0 i_0 \cos \phi \Rightarrow 1000 = \frac{1}{2} \times 200 \times i_0 \cos 60^\circ$$

$$\Rightarrow i_0 = 20 \text{ A} \Rightarrow i_{\text{rms}} = \frac{i_0}{\sqrt{2}} = \frac{20}{\sqrt{2}} = 10\sqrt{2} \text{ A}$$

222 (c)

$$Q = \frac{\omega L}{R} = \frac{1}{R} \times \frac{1}{\sqrt{LC}} \times L$$

$$= \frac{1}{R} \sqrt{\frac{L}{C}}$$

$$= \frac{1}{3} \times \sqrt{\frac{1}{9}} = \frac{1}{9}$$

223 (c)

Given,  $V_R = 5 \text{ V}$ ,  $V_L = 10 \text{ V}$  and  $V_C = 10 \text{ V}$

In the  $L - C - R$  circuit, the AC voltage applied to the circuit will be

$$V = \sqrt{V_R^2 + (V_L - V_C)^2}$$

$$= \sqrt{(5)^2 + (10 - 10)^2} = 5 \text{ V}$$

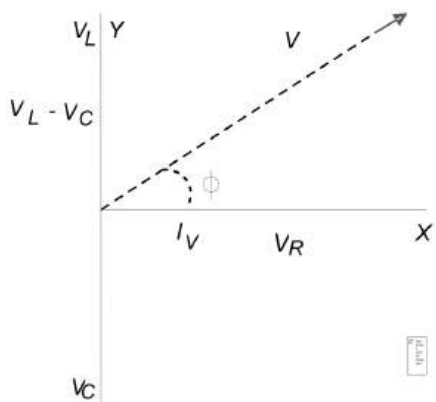

224 (b)

The impedance of  $R - C$  circuit for frequency  $f_1$  is

$$Z_1 = \sqrt{R^2 + \frac{1}{4\pi^2 f^2 C^2}}$$

The impedance of  $R - C$  circuit for frequency  $2f$  is

$$Z_2 = \sqrt{R^2 + \frac{1}{4\pi^2 (2f)^2 C^2}}$$

or 
$$Z_2 = \sqrt{R^2 + \frac{1}{16\pi^2 f^2 C^2}}$$

Then, 
$$\frac{Z_1^2}{Z_2^2} = \frac{R^2 + \frac{1}{4\pi^2 f^2 C^2}}{R^2 + \frac{1}{16\pi^2 f^2 C^2}}$$

Or 
$$\frac{Z_1^2}{Z_2^2} = \frac{1 + \frac{1}{4\pi^2 f^2 C^2 R^2}}{1 + \frac{1}{16\pi^2 f^2 C^2 R^2}}$$

Values are greater than 1 then  $\frac{Z_1}{Z_2}$  lies between 1 and 2.

225 (c)

$$f = \frac{1}{2\pi\sqrt{LC}}$$

$$\therefore f = \frac{1}{2 \times 3.14 \sqrt{0.5 \times 10^{-3} \times 20 \times 10^{-6}}}$$

$$= \frac{1}{2 \times 3.14 \times 10^{-4}} \approx 1600 \text{ Hz}$$

226 (c)

$$\tan \phi = \frac{X_L}{R} = \frac{2\pi\nu L}{R} = \frac{2\pi \times \frac{200}{2\pi} \times 1}{200} = 1 \Rightarrow \phi = 45^\circ$$

227 (a)

$$e = L \frac{di}{dt} = 2 \times 10^{-3} = 2V$$

228 (d)

$$P_{av} = \frac{V_{rms}^2 R}{Z^2}$$

229 (b)

$$V_0 = i_0 Z \Rightarrow 200 = 100 Z \Rightarrow Z = 2\Omega$$

$$\text{Also } Z^2 = R^2 + X_L^2 \Rightarrow (2)^2 = (1)^2 + X_L^2 \Rightarrow X_L = \sqrt{3}\Omega$$

231 (b)

$$\text{Power loss} \propto \frac{1}{(\text{Voltage})^2}$$

232 (c)

Resistances of both the bulbs are

$$R_1 = \frac{V^2}{P_1} = \frac{220^2}{25}$$

$$R_2 = \frac{V^2}{P_2} = \frac{220^2}{100}$$

$$\therefore R_2 > R_1$$

Hence 25 W bulb will fuse

233 (b)

$$i = \frac{V - E}{R}, R = \frac{V - E}{i} = \frac{220 - 80}{25} = 5.6 \Omega$$

234 (c)

The current in  $LCR$  circuit becomes maximum at series resonance condition. At this point the total reactance of the circuit is zero. That means the reactance of inductance becomes equal and opposite to the reactance by the capacitor

235 (b)

For anti-resonant circuit current is minimum at resonant frequency and at frequencies other than resonant frequency current rises with frequency

237 (b)

$$P = Vi \cos \phi = V \left(\frac{V}{Z}\right) \left(\frac{R}{Z}\right) = \frac{V^2 R}{Z^2} = \frac{V^2 R}{R^2 + \omega^2 L^2}$$

238 (b)

Moving from A to B.

$$V_B - V_A = [5 \times 10^{-3}(-10^3) + 15 + 1 \times 5] = 15 \text{ volt}$$

239 (d)

For a series  $L - C - R$  circuit at resonance

Phase difference,  $\phi = 0^\circ$

Power factor =  $\cos \phi = 1$

241 (c)

Resonance frequency in *radian/second* is

$$\omega = \frac{1}{\sqrt{LC}} = \frac{1}{\sqrt{8 \times 0.5 \times 10^{-6}}} = 500 \text{ rad/sec}$$

242 (b)

$$X_C = \frac{1}{\omega C} = \frac{1}{2\pi f C}$$

$$\text{i.e., } X_C \propto \frac{1}{f}$$

243 (b)

$$Z = \sqrt{R^2 + X_C^2} : I_{rms} = \frac{V_{rms}}{Z} : P = I_{rms}^2 R$$

$$\text{Where } X_C = \frac{1}{\omega C}$$

As  $\omega$  is increased,  $X_C$  will decrease or  $Z$  will decrease. Hence  $I_{rms}$  or  $P$  will increase.

Therefore, bulb glows brighter.

Hence the correct option is (b).

244 (d)

$$C = \frac{t}{R} = \frac{10}{10^3} = 10^{-2} F = 10^4 \mu F$$

245 (c)

$$2\pi v = 377 \Rightarrow v = 60.03 \text{ Hz}$$

247 (c)

$$f = \frac{1}{2\pi\sqrt{LC}}$$

or  $f \propto \frac{1}{\sqrt{C}}$

When capacitor C is replaced by another capacitor C' of dielectric constant K, then

$$C' = KC$$

$$\therefore \frac{f'}{f} = \sqrt{\frac{C}{C'}}$$

or  $\frac{125000 - 25000}{125000} = \sqrt{\frac{C}{KC}}$

or  $\frac{100}{125} = \frac{1}{\sqrt{K}}$

or  $K = \left(\frac{125}{100}\right)^2 = 1.56$

248 (a)

$$\frac{E_S}{E_P} = \frac{i_P}{i_S} \Rightarrow i_P = \frac{E_S}{E_P} \times i_S = \frac{4.6}{230} \times 5 = 0.1 \text{ A}$$

Frequency is not affected by transformer.

249 (a)

$$V_{av} = \frac{2}{\pi} V_0 = \frac{2}{\pi} \times (V_{rms} \times \sqrt{2}) = \frac{2\sqrt{2}}{\pi} \cdot V_{rms}$$

$$= \frac{2\sqrt{2}}{\pi} \times 220 = 198 \text{ V}$$

250 (b)

Ist case From formula

$$R = \frac{V^2}{P}$$

$$= \frac{110 \times 110}{330} = \frac{110}{3} \Omega$$

Since, current lags the voltage thus, the circuit contains resistance and inductance.

Power factor  $\cos \phi = 0.6$

$$\frac{R}{\sqrt{R^2 + X_L^2}} = 0.6$$

$$\Rightarrow R^2 + X_L^2 = \left(\frac{R}{0.6}\right)^2$$

$$\Rightarrow X_L^2 = \frac{R^2}{(0.6)^2} - R^2$$

$$\Rightarrow X_L^2 = \frac{R^2 \times 0.64}{0.36}$$

$$\therefore X_L = \frac{0.8R}{0.6} = \frac{4R}{3} \quad \dots(i)$$

IInd case

Now  $\cos \phi = 1$  (given)

Therefore, circuit is purely resistive, i.e, it contains only resistance. This is the condition of resonance in which

$$X_L = X_C$$

$$\therefore X_C = \frac{4R}{3} = \frac{4}{3} \times \frac{110}{3} = \frac{440}{9} \Omega \quad [\text{From Eq.}]$$

(i)]

$$\frac{1}{2\pi f C} = \frac{440}{9} \Omega$$

$$C = \frac{9}{2 \times 3.14 \times 60 \times 440}$$

$$= 54 \mu F$$

251 (b)

Capacitive reactance ( $X_C$ ) is given by

$$X_C = \frac{1}{\omega C}$$

Where  $\omega$  is angular frequency and C the capacitance.

Also,  $\omega = 2\pi f$ , where f is frequency.

In a DC circuit  $f = 0 \therefore \omega = 0$

$$X_C = \frac{1}{0} = \infty$$

252 (c)

As continuous flow of DC do not take place through a capacitor, Therefore resistance of the circuit

$$R = 1 + 0.5 = 1.5$$

Current with circuit

$$E = \frac{E}{R'}$$

$$= \frac{2}{1.5} = \frac{4}{3} \text{ A}$$

Potential difference across capacitor = Potential difference across 1  $\Omega$  resistor

$$= \frac{4}{3} \times 1 = \frac{4}{3} \text{ V}$$

$\therefore$  Charge on capacitor  $q = CV$

$$= 1 \times \frac{4}{3} = 1.33 \mu F$$

253 (a)

Frequency of LC oscillation =  $\frac{1}{2\pi\sqrt{LC}}$

$$\Rightarrow \frac{f_1}{f_2} = \frac{1}{\sqrt{L_1 C_1}} \sqrt{L_2 C_2} = \left(\frac{L_2 C_2}{L_1 C_1}\right)^{1/2}$$

$$= \left(\frac{2L \times 4C}{L \times C}\right)^{1/2} = (8)^{1/2}$$

$$\therefore \frac{f_1}{f_2} = 2\sqrt{2} \Rightarrow f_2 = \frac{f_1}{2\sqrt{2}} \text{ or } f_2 = \frac{f}{2\sqrt{2}} \quad [\because f_1 = f]$$

254 (a)

From  $e = L \frac{di}{dt}$

$$\frac{di}{dt} = \frac{e}{L} = \frac{90}{0.2} = 450 \text{ As}^{-1}$$

255 (d)

$$V = 120 \sin 100\pi t \cos 100\pi t \Rightarrow V = 60 \sin 200\pi t$$

$$V_{\max} = 60 \text{ V and } v = 100 \text{ Hz}$$

256 (c)

Power = Rate of work done in one complete cycle.

or  $P_{av} = \frac{W}{T}$

or  $P_{av} = \frac{(E_0 I_0 \cos \phi) T / 2}{T}$

or  $P_{av} = \frac{E_0 I_0 \cos \phi}{2}$

Where  $\cos \phi$  is called the power factor of an AC circuit.

257 (b)

The impedance ( $Z$ ) of an  $R-L-C$  series circuit is given by

$$Z = \sqrt{R^2 + \left(\omega L - \frac{1}{\omega C}\right)^2}$$

As frequency of alternating emf applied to the circuit is increased,  $X_L$  goes on increasing and  $X_C$  goes on decreasing.

For a particular value of  $\omega = (\omega_r \text{ say})$

$$X_L = X_C$$

i.e.,  $\omega_r L = \frac{1}{\omega_r C}$

or  $\omega_r = \frac{1}{\sqrt{LC}}$

or  $2\pi v_r = \frac{1}{\sqrt{LC}}$

or  $v_r = \frac{1}{2\pi\sqrt{LC}}$

$$\begin{aligned} \therefore v &= \frac{1}{2 \times 3.14 \times \sqrt{5 \times 80 \times 10^{-6}}} \\ &= \frac{1}{2 \times 3.14 \times \sqrt{(400 \times 10^{-6})}} \\ &= \frac{1}{2 \times 3.14 \times 2 \times 10^{-2}} \\ &= \frac{100}{3.14 \times 4} \\ &= \frac{25}{3.15} = \frac{25}{\pi} \text{ Hz} \end{aligned}$$

259 (b)

The time taken by AC in reaching from zero to maximum value is

$$\begin{aligned} t &= \frac{T}{4} = \frac{1}{4f} \\ &= \frac{1}{50 \times 4} = 5 \times 10^{-3} \text{ s} \end{aligned}$$

260 (b)

For given circuit current is lagging the voltage by  $\pi/2$ , so circuit is purely inductive and there is no power consumption in the circuit. The work done by battery is stored as magnetic energy in the inductor.

262 (a)

In a pure inductor (zero resistance), voltage leads the current by  $90^\circ$  i.e.,  $\pi/2$

263 (d)

$$P = Vi \cos \phi$$

$$\text{Phase difference } \phi = \frac{\pi}{2} \Rightarrow P = \text{zero}$$

264 (c)

$$\text{We have } X_C = \frac{1}{C \times 2\pi f} \text{ and } X_L = L \times 2\pi f$$

265 (c)

$$\text{Here } I_{rms} = 10 \text{ A, } R = 12 \Omega$$

The maximum current is

$$I_m = \sqrt{2} I_{rms} = \sqrt{2}(10) = 10\sqrt{2} \text{ A}$$

$$\begin{aligned} \text{Maximum potential difference is } V_m &= I_m R \\ &= 10\sqrt{2} \times 12 = 169.68 \text{ V} \end{aligned}$$

266 (b)

$$\begin{aligned} Z &= \sqrt{R^2 + X_C^2} \\ &= \sqrt{(R)^2 + \left(\frac{1}{\omega C}\right)^2} \end{aligned}$$

In case (b) capacitance ( $c$ ) will be more. Therefore, impedance  $Z$  will be less. Hence current will be more.

267 (c)

$$\tan \phi = \frac{X_L}{R} = 1 \therefore \phi = 45^\circ \text{ or } \pi/4$$

268 (c)

(i) In a circuit having  $C$  alone, the voltage lags the current by  $\frac{\pi}{2}$ .

(ii) In a circuit containing  $R$  and  $L$ , the voltage leads the current by  $\frac{\pi}{2}$ .

(iii) In  $L-C$  circuit, the phase difference between current and voltage can have any

value between  $0$  to  $\frac{\pi}{2}$  depending on the

values of  $L$  and  $C$ .

(iv) In a circuit containing  $L$  alone, the voltage leads the current by  $\frac{\pi}{2}$ .

269 (d)

$$\text{Induced emf } e = Blv = BWv$$

$$\text{Power developed} = \frac{e^2}{R} = \frac{B^2 W^2 v^2}{R}$$

270 (b)

In  $RC$  series circuit voltage across the capacitor leads the voltage across the resistance by  $\frac{\pi}{2}$

271 (c)

$$E_S = \frac{n_s}{n_p} E_P = \frac{1}{200} \times 240 = 12 \text{ V}$$

272 (a)

$$\begin{aligned} \text{The current is } I &= \frac{E_0}{\sqrt{R^2 + \omega^2 L^2}} \\ &= \frac{4}{\sqrt{4^2 + (1000 \times 3 \times 10^{-3})^2}} = 0.8 \text{ A} \end{aligned}$$

273 (b)

In parallel resonant circuit, resonance frequency

$$\begin{aligned} f_0 &= \frac{1}{2\pi\sqrt{LC}} \\ &= \frac{1}{2\pi\sqrt{\frac{10 \times 10^{-3}}{\pi^2} \times 0.04 \times 10^{-6}}} \\ &= \frac{10^4}{2 \times 0.2} = 25 \text{ kHz} \end{aligned}$$

274 (d)



$$V_{rms} = \sqrt{\frac{(T/2)V_0^2 + 0}{T}} = \frac{V_0}{\sqrt{2}}$$

275 (a)

The voltage across a  $L - R$  combination is given by

$$V^2 = V_R^2 + V_L^2$$

$$V_L = \sqrt{V^2 - V_R^2} = \sqrt{400 - 144} = \sqrt{256} = 16 \text{ volt}$$

276 (d)

The average power of  $L - C - R$  circuit

$$P_{av} = V_{rms} \cdot i_{rms} \cos \phi$$

Hence, the average power depends upon current, emf and phase difference.

277 (d)

$$X_L = 2\pi v L \Rightarrow L = \frac{X_L}{2\pi v} = \frac{50}{2 \times 3.14 \times 50} = 0.16 \text{ H}$$

278 (d)

The average power dissipation in the circuit is

$$\frac{1}{2} E_0 I_0 \tan \phi$$

279 (a)

Final current in constant and  $L$  plays no role at that instant. Therefore,  $i = E/R$ .

280 (a)

A closed current carrying loop of any irregular shape and even not lying in a single plane, placed in a uniform magnetic field shall experience no net force. Therefore, force acting on the loop must be zero.

281 (b)

$$\text{As } M = \frac{\mu_0 N_1 N_2 A}{l},$$

$\therefore M$  can be increased by increasing the number of turns in the coils.

282 (a)

In  $L-C-R$  series circuit,

$$\begin{aligned} V &= \sqrt{V_R^2 + (V_L - V_C)^2} \\ &= \sqrt{(40)^2 + (60 - 30)^2} \\ &= \sqrt{1600 + 900} = \sqrt{2500} = 50V \end{aligned}$$

283 (c)

For series  $L - C - R$  circuit

$$\begin{aligned} V &= \sqrt{V_R^2 + (V_L - V_C)^2} \\ &= \sqrt{(80)^2 + (40 - 100)^2} \\ &= 100 \text{ V} \end{aligned}$$

285 (b)

$$\text{Power } P = \frac{1}{2} V_0 I_0 \cos \phi$$

$$\begin{aligned} &= 0.5 \times 150 \times 150 \times \cos 60^\circ = \frac{22500}{4} \\ &= 5625 \text{ W} \end{aligned}$$

286 (a)

If the capacitance is removed, it is an  $L - R$  circuit  $\phi = 60^\circ$

$$\tan \phi = \frac{X_L}{R} = \tan 60^\circ = \sqrt{3}$$

If inductance is removed, it is a capacitive circuit or  $R - C$  circuit.  $|\phi|$  is the same

$$\therefore L\omega = \frac{1}{C\omega} \text{ This is a resonance circuit}$$

$$Z = R; I_{rms} = \frac{E_{rms}}{R}, E_{rms} = 200 \text{ V}$$

$$\therefore I_{rms} = \frac{200V}{100\Omega} = 2A$$

287 (d)

Resistance of the bulb

$$R = \frac{V^2}{P} = \frac{(100)^2}{50} = 200 \Omega$$

$$\begin{aligned} \text{Current through bulb } (I) &= \frac{V}{R} \\ &= \frac{100}{200} = 0.5 \text{ A} \end{aligned}$$

In a circuit containing inductive reactance ( $X_L$ ) and resistance ( $R$ ), impedance ( $Z$ ) of the circuit is

$$Z = \sqrt{R^2 + \omega^2 L^2} \quad \dots(i)$$

$$\text{Here, } Z = \frac{200}{0.5} = 400 \Omega$$

$$\begin{aligned} \text{Now, } X_L^2 &= Z^2 - R^2 \\ &= (400)^2 - (200)^2 \end{aligned}$$

$$(2\pi f L)^2 = 12 \times 10^4$$

$$\begin{aligned} L &= \frac{2\sqrt{3} \times 100}{2\pi \times 50} \\ &= \frac{2\sqrt{3}}{\pi} = 1.1 \text{ H} \end{aligned}$$

288 (b)

The  $Q$ -factor of series resonant circuit is given by

$$Q = \frac{\omega^2 L}{R}$$

It is evident from the relation that as  $R$  is increased,  $Q$ -factor of the circuit is decreased.

289 (d)

In steady state current through the branch having capacitor is zero.

$$\therefore \frac{1}{R} = \frac{1}{1} + \frac{1}{2} + \frac{1}{3}$$

$$\frac{1}{R} = \frac{6 + 3 + 2}{6}$$

$$R = \frac{6}{11}$$

$$\text{As } V = iR$$

$$\therefore 6 = i \times \frac{6}{11}$$

Current through the battery  $i = 11A$

Charge on the capacitor  $q = CV$   
 $\Rightarrow q = 0.5 \times 10^{-6} \times 6$   
 $q = 3\mu C$

290 (d)

Current will be maximum in the condition of resonance so  $i_{\max} = \frac{V}{R} = \frac{V}{10} A$

Energy stored in the coil  $W_L = \frac{1}{2} Li_{\max}^2 = \frac{1}{2} L \left(\frac{E}{10}\right)^2$   
 $= \frac{1}{2} \times 10^{-3} \left(\frac{E^2}{100}\right) = \frac{1}{2} \times 10^{-5} E^2 \text{ joule}$

$\therefore$  Energy stored in the capacitor

$W_C = \frac{1}{2} CE^2 = \frac{1}{2} \times 2 \times 10^{-6} E^2 = 10^{-6} E^2 \text{ joule}$

$\therefore \frac{W_C}{W_L} = \frac{1}{5}$

291 (c)

$X_L = 2\pi\nu L = 2 \times \pi \times 50 \times \frac{1}{\pi} = 100\Omega$

293 (c)

In series  $R-L-C$  circuit, the impedance of the circuit is given by

$Z = \sqrt{R^2 + (X_L - X_C)^2}$

Also,  $X_L = \omega L$ ,  $X_C = \frac{1}{\omega C}$

$\therefore Z = \sqrt{R^2 + \left(\omega L - \frac{1}{\omega C}\right)^2}$

Given,  $R = 300\Omega$ ,  $\omega = 1000 \text{ rads}^{-1}$ ,  $L = 0.9 H$ ,  
 $C = 20\mu F = 2 \times 10^{-6} F$

Hence,  $Z = \sqrt{(300)^2 + \left(1000 \times 0.9 - \frac{1}{1000 \times 2 \times 10^{-6}}\right)^2}$   
 $= \sqrt{90000 + (900 - 500)^2}$   
 $= \sqrt{90000 + 160000}$   
 $= \sqrt{250000} = 500 \Omega$

294 (b)

As coil  $A$  is moved closer to  $B$ , field due to  $A$  intercepting  $B$  is increasing. Induced current in  $B$  must oppose this increase. Hence the current in  $B$  must be anti-clock-wise.

295 (d)

Reactance  $X = X_L - X_C = 2\pi fL - \frac{1}{2\pi fC}$

296 (d)

Circuit is resonant.

Hence supply voltage equals

$V_R = 10 V$

Also,  $X_C = R$

As the voltage drops are equals across them when  $L$  is shortened

$Z = \sqrt{R^2 + X_C^2} = \sqrt{2R}$

$V_C = iX_C$  ( $\because i = \frac{V}{Z}$ )

or  $V_C = \frac{V}{Z} X_C = \frac{10}{\sqrt{2R}} R$

$V_C = \frac{10}{\sqrt{2}} V$

297 (c)

Adff sdfsd sdfsd dsf

298 (b)

From  $e = L di/dt$ ,  $L = \frac{edt}{di} = \frac{8 \times 0.05}{2} = 0.2H$

299 (a)

Capacitance of wire

$C = 0.014 \times 10^{-6} \times 200$

$= 2.8 \times 10^{-6} F = 2.84\mu F$

For impedance of the circuit to be minimum

$X_L = X_C$

$\Rightarrow 2\pi\nu L = \frac{1}{2\pi\nu C}$

$L = \frac{1}{4\pi^2\nu^2 C}$

$= \frac{1}{4(3.14)^2 \times (5 \times 10^3)^2 \times 2.8 \times 10^{-6}}$

$= 0.35 \times 10^{-3} H = 0.35 \text{ mH}$

300 (c)

At resonance  $X_L = X_C$

303 (c)

As  $B_0 = \mu_0 ni$ , therefore  $B_0$  does not depend upon radius ( $r$ ) of the solenoid.

304 (c)

Here,  $L = 25 \text{ mH} = 25 \times 10^{-3} H$

$\nu = 50 \text{ Hz}$ ,  $V_{rms} = 220 V$

The inductive reactance is

$X_L = 2\pi\nu L = 2 \times \frac{22}{7} \times 50 \times 25 \times 10^{-3} \Omega$

The  $rms$  current in the circuit is

$I_{rms} = \frac{V_{rms}}{X_L} = \frac{220}{2 \times \frac{22}{7} \times 50 \times 25 \times 10^{-3}}$

$= \frac{7 \times 1000}{2 \times 5 \times 25} A = 28 A$

305 (b)

To decrease current in an AC circuit, choke coil is used. The choke coil has high inductance and negligible resistance, so that the energy loss in the circuit is negligible.

Hence,  $X_L \gg R$

306 (a)

Current in a  $L-C-R$  series circuit,

$i = \frac{V}{\sqrt{R^2 + (X_L - X_C)^2}}$

Where  $V$  is rms value of current,  $R$  is resistance,  $X_L$  is inductive reactance and  $X_C$  is capacitive reactance.

For current to be maximum, denominator should be minimum which can be done, if

$$X_L = X_C$$

This happens in resonance state of the circuit

*i.e.*,  $\omega L = \frac{1}{\omega C}$

or  $L = \frac{1}{\omega^2 C}$  ... (i)

Given,  $\omega = 1000\text{s}^{-1}$ ,  $C = 10\mu\text{F} = 10 \times 10^{-6}\text{F}$

Hence,  $L = \frac{1}{(1000)^2 \times 10 \times 10^{-6}} = 0.1\text{H} = 100\text{mH}$

307 (b)

$$\begin{aligned} E &= E_0 \cos \omega t = 10 \cos(2\pi \times ft) \\ &= 10 \cos\left(2\pi \times 50 \times \frac{1}{600}\right) \\ &= 10 \cos\left(\frac{\pi}{6}\right) = 10 \times \frac{\sqrt{3}}{2} = 5\sqrt{3}\text{V} \end{aligned}$$

309 (d)

As explained in solution (1) for frequency  $0 - f_r$ ,  $Z$  decreases hence ( $i = V/Z$ ) increases and for frequency  $f_r - \infty$ ,  $Z$  increases hence  $i$  decreases

310 (a)

At resonance,  $V_L$  and  $V_C$  are equal in magnitude but have phase difference of  $180^\circ$  relative to each other

$$\therefore V_{LC} = V_L - V_C = 0$$

Hence, voltmeter  $V_2$  read 0 volt

311 (b)

When  $C$  is removed circuit becomes  $RL$  circuit hence

$$\tan \frac{\pi}{3} = \frac{X_L}{R} \quad \dots (i)$$

When  $L$  is removed circuit becomes  $RC$  circuit hence

$$\tan \frac{\pi}{3} = \frac{X_C}{R} \quad \dots (ii)$$

From equation (i) and (ii) we obtain  $X_L = X_C$ .

This is the condition of resonance and in

resonance  $Z = R = 100\Omega$

312 (c)

$$V_L = 46\text{volts}, V_C = 40\text{volts}, V_R = 8\text{volts}$$

$$\text{E.M.F. of source } V = \sqrt{8^2 + (46 - 40)^2} = 10\text{volts}$$

313 (b)

$$\begin{aligned} \text{Resonance frequency, } \omega &= \frac{1}{\sqrt{LC}} \\ &= \frac{1}{\sqrt{8 \times 10^{-3} \times 20 \times 10^{-6}}} \\ &= \frac{1}{4 \times 10^{-4}} = \frac{10^4}{4} \\ &= 2500\text{rad s}^{-1} \end{aligned}$$

$$\text{Amplitude of current, } I_0 = \frac{V}{R} = \frac{220}{44} = 5\text{A}$$

314 (a)

$$V_{rms} = \sqrt{\frac{1}{T} \int_0^T 10^2 dt} = 10\text{V}$$

315 (c)

$$\text{Effective voltage } V_{r.m.s.} = \frac{V_0}{\sqrt{2}} = \frac{423}{\sqrt{2}} = 300\text{V}$$

316 (b)

Given,  $L = 20\text{mH} = 20 \times 10^{-3}\text{H}$

$$C = 50\mu\text{F} = 50 \times 10^{-6}\text{F}$$

For  $LC$  circuit the frequency,

$$f = \frac{1}{2\pi\sqrt{LC}}$$

or  $T = 2\pi\sqrt{LC} \quad (\because T = \frac{1}{f})$

At time  $t = \frac{T}{4}$ , energy stored is completely magnetic.

The time,  $t = \frac{T}{4}$

$$t = \frac{2\pi\sqrt{LC}}{4}$$

or  $t = \frac{2\pi\sqrt{20 \times 10^{-3} \times 50 \times 10^{-6}}}{4}$

or  $t = \frac{3.14\sqrt{10^{-6}}}{2}$

or  $t = \frac{3.14 \times 10^{-3}}{2}$

or  $t = 1.57 \times 10^{-3}\text{s} = 1.57\text{ms}$

317 (c)

Ignoring mutual induction, resultant, inductance

$$L' = L_1 + L_2$$

$$= L + L = 2L$$

319 (a)

In an  $L - C$  circuit the impedance of circuit is

$$Z = X_L - X_C$$

When  $X_L = X_C$ , then  $Z = 0$ . In this situation the

amplitude of current in the circuit would be

infinite. It will be condition of electrical resonance

and frequency is given by

$$\begin{aligned} f &= \frac{1}{2\pi\sqrt{LC}} \\ &= \frac{1}{2 \times 3.14 \times \sqrt{10 \times 10^{-3} \times 0.25 \times 10^{-6}}} \\ &= 3184.7\text{ cycle s}^{-1} \end{aligned}$$

Also frequency =  $\frac{\text{velocity}}{\text{wavelength}}$

$$\Rightarrow \lambda = \frac{c}{f} = \frac{3 \times 10^8}{3184.7}$$

$$\Rightarrow \lambda = 9.42 \times 10^4\text{m}$$

320 (a)

As the inductors are in parallel, therefore, induced emf across the two inductors is the same *i.e.*,

$$e_1 = e_2$$

$$L_1 \left( \frac{di_1}{dt} \right) = L_2 \left( \frac{di_2}{dt} \right)$$

Integrating both sides w.r.t.  $t$ , we get

$$L_1 i_1 = L_2 i_2$$

$$\therefore \frac{i_1}{i_2} = \frac{L_2}{L_1}$$

321 (a)

Impedance,

$$Z = \sqrt{R^2 + (X_L - X_C)^2}$$

$$\therefore 10 = \sqrt{(10^2 + (X_L - X_C)^2)}$$

$$\Rightarrow 100 = 100 + (X_L - X_C)^2$$

$$\Rightarrow X_L - X_C = 0$$

...(i)

Let  $\phi$  is the phase difference between current and voltage

$$\tan \phi = \frac{X_L - X_C}{R}$$

$$\therefore \tan \phi = \frac{0}{R}$$

$$\Rightarrow \phi = 0 \quad [\text{From Eq.(i)}]$$

322 (d)

In an  $L - C - R$  series AC circuit, the voltage across inductor  $L$  leads the current by  $90^\circ$  and the voltage across capacitor  $C$  lags behind the current by  $90^\circ$ .

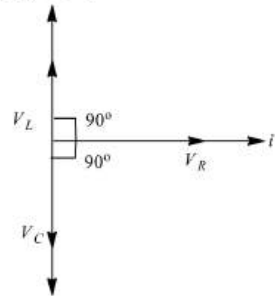

Hence, the voltage across  $L - C$  combination will be zero.

323 (d)

$$L = \frac{\mu_0 N^2 A}{l} = \frac{\mu_0 N^2 (\pi r^2)}{l}$$

$$= \frac{4\pi \times 10^{-7} \times (500)^2 \times \pi (0.025)^2}{1}$$

$$= 4 \times 10 \times 10^7 \times (500)^2 \times (0.025)^2$$

$$= 6.25 \times 10^{-4} \text{H}$$

325 (c)

The power loss in AC circuit will be minimum, if resistance is low. In inductance power loss is zero. It applies to high as well as low inductances.

326 (c)

$$\text{Inductive reactance } X_L = \omega L$$

$$= 2\pi \nu L$$

$$= 2\pi \times 50 \times 1$$

$$= 100\pi$$

327 (d)

A series resonance circuit admits maximum current, as

$$P = i^2 R$$

So, power dissipated is maximum at resonance.

So, frequency of the source at which maximum power is dissipated in the circuit is

$$\begin{aligned} \nu &= \frac{1}{2\pi\sqrt{LC}} \\ &= \frac{1}{2 \times 3.14 \sqrt{25 \times 10^{-3} \times 400 \times 10^{-6}}} \\ &= \frac{1}{2 \times 3.14 \sqrt{10^{-5}}} = 50.3 \text{ Hz} \end{aligned}$$

328 (a)

As initially charge is maximum,

$$q = q_0 \cos \omega t$$

$$\Rightarrow i = \frac{dq}{dt} = -\omega q_0 \sin \omega t$$

$$\text{Given } \frac{1}{2} Li^2 = \frac{q^2}{2C}$$

$$\Rightarrow \frac{1}{2} L (\omega q_0 \sin \omega t)^2 = \frac{(q_0 \cos \omega t)^2}{2C}$$

$$\omega = \frac{1}{\sqrt{LC}}$$

$$\therefore \tan \omega t = 1$$

$$\omega t = \tan^{-1} 1$$

$$t = \frac{\pi}{4\omega} = \frac{\pi}{4} \sqrt{LC}$$

330 (b)

(1) For time interval  $0 < t < T/2$

$I = kt$ , where  $k$  is the slope

For inductor as we know, induced voltage  $V =$

$$-L \frac{di}{dt}$$

$$\Rightarrow V_1 = -KL$$

(2) For time interval  $\frac{T}{2} < t < T$

$$I = -Kt \Rightarrow V_2 = KL$$

331 (c)

Average power in AC circuits is given by  $P =$

$V_{\text{rms}} I_{\text{rms}} \cos \phi$  for pure capacitive circuit  $\phi = 90^\circ$  so,  $P = 0$ .

332 (d)

$$I_L = \frac{V}{X_L} \text{ and } I_C = \frac{V}{X_C}$$

$$\text{i.e., } I_L \propto \frac{1}{\omega}$$

$$\text{and } I_C \propto \omega$$

$\therefore$  With increase in  $\omega$ ,  $I_L$  decreases while  $I_C$  increases.

333 (a)

Geometric length of a magnet is  $6/5$  times its magnetic length.

$$\therefore \text{Geometric length} = 6/5 \times 10 = 12 \text{ cm}$$

334 (c)

The current in the circuit

$$i = \frac{V_R}{R} = \frac{100}{1000} = 0.1 \text{ A}$$

At resonance,

$$V_L = V_C = iX_C = \frac{i}{\omega C} = \frac{0.1}{200 \times 2 \times 10^{-6}} = 250 \text{ V}$$

335 (d)

Given, the frequency of alternating current  $f = 50 \text{ Hz}$

The time for alternating current to become its rms value from zero.

$$t = \frac{T}{4}$$

or  $t = \frac{1}{4f}$

or  $t = \frac{1}{200} \text{ s}$

or  $t = 5 \text{ ms}$

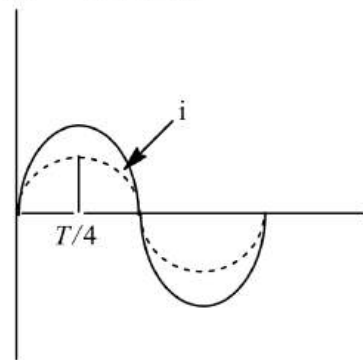

336 (c)

The full cycle of alternating current consists of two half cycles. For one - half, current is positive and for second half, current is negative. Therefore, for an AC cycle, the net value of current average out to zero. While the DC ammeter, read the average value. Hence, the alternating current cannot DC measured by DC ammeter.

337 (a)

Current will be maximum at the condition of resonance. So resonant frequency  $\omega_0 = \frac{1}{\sqrt{LC}} =$

$$\frac{1}{\sqrt{0.5 \times 8 \times 10^{-6}}} = 500 \text{ rad/s}$$

338 (c)

Input power  $P_1 = 220 \times 1.5 = 330 \text{ W}$

Loss of power  $i^2 R = \left(\frac{3}{2}\right)^2 \times 20 = 45 \text{ W}$

Output power,  $P_0 = 330 - 45 = 285 \text{ W}$

$\therefore$  Peak emf induced,  $V_0 = \frac{P_0}{i} = \frac{285}{1.5} = 190 \text{ V}$

339 (c)

$$V_{rms} = \frac{V_0}{\sqrt{2}} = \frac{770\sqrt{2}}{2} \approx 500 \text{ V}$$

340 (c)

In  $L - R$  circuit, impedance

$$Z = \sqrt{R^2 + X_L^2}$$

Here,  $X_L = \omega L = 2\pi fL$

$$\therefore Z = \sqrt{R^2 + 4\pi^2 f^2 L^2}$$

341 (a)

Given,  $V_C = 3V_R = 3(V - V_C)$

Here,  $V$  is the applied potential.

$$\therefore V_C = \frac{3}{4} V$$

$$\text{Or } V(1 - e^{-t/\tau_c}) = \frac{3}{4} V$$

$$\therefore e^{-t/\tau_c} = \frac{1}{4} \quad \dots (i)$$

Here,  $\tau_c = CR = 10 \text{ s}$

Substituting this value of  $\tau_c$  in Eq.(i) and solving for  $t$  we get

$$t = 13.8 \text{ s}$$

342 (d)

$$I_1 = \frac{E}{R_1} = \frac{12}{2} = 6 \text{ A}$$

$$E = L \frac{dI_2}{dt} + R_2 \times I_2$$

$$I_2 = I_0(1 - e^{-t/\tau_c})$$

$$\Rightarrow I_0 = \frac{E}{R_2} = \frac{12}{2} = 6 \text{ A}$$

$$\tau_c = \frac{L}{R} = \frac{400 \times 10^{-3}}{2} = 0.2$$

$$I_2 = 6(1 - e^{-t/0.2})$$

Potential drop across

$$L = E - R_2 I_2 = 12 - 2 \times 6(1 - e^{-bt}) = 12e^{-5t}$$

343 (c)

Reactance of capacitor or capacitive reactance is denoted by  $X_C$ , given by

$$X_C = \frac{1}{\omega C}$$

Given,  $\omega = 50 \text{ rad s}^{-1}$ ,  $C = 50 \mu\text{F} = 50 \times 10^{-6} \text{ F}$

$$\therefore X_C = \frac{1}{50 \times 50 \times 10^{-6}}$$

From Ohm's law, current flowing through the circuit is given by

$$I_{rms} = \frac{V_{rms}}{X_C} = \frac{220}{1/50 \times 50 \times 10^{-6}}$$

$$\Rightarrow I_{rms} = 220 \times 50 \times 50 \times 10^{-6} = 55 \times 10^{-2} \text{ A} = 0.55 \text{ A}$$

344 (a)

In an ideal choke, ratio of its inductance  $L$  to its DC resistance  $R$  is infinity.

345 (a)

Given,  $R = 3\Omega$ ,  $X_L = 15\Omega$ ,  $X_C = 11\Omega$

$$V_{\text{rms}} = 10 \text{ volt}$$

$\therefore$  Current through the circuit

$$\begin{aligned} i &= \frac{V_{\text{rms}}}{\sqrt{R^2 + (X_L - X_C)^2}} \\ &= \frac{10}{\sqrt{(3)^2 + (15 - 11)^2}} \\ &= \frac{10}{\sqrt{9 + 16}} = \frac{10}{5} = 2 \text{ A} \end{aligned}$$

Since,  $L$ ,  $C$  and  $R$  are connected in series combination then potential difference across  $R$  is

$$V_R = i \times R = 2 \times 3 = 6 \text{ V}$$

Across  $L$ ,  $V_L = iX_L = 2 \times 15 = 30 \text{ V}$

Across  $C$ ,  $V_C = iX_C = 2 \times 11 = 22 \text{ V}$

So, potential difference across series combination of  $L$  and  $C$ ,

$$\begin{aligned} &= V_L - V_C \\ &= 30 - 22 = 8 \text{ V} \end{aligned}$$

346 (d)

At resonance net voltage across  $L$  and  $C$  is zero

347 (d)

$$\therefore P = Vi \cos \phi, \therefore P \propto \cos \phi$$

348 (b)

$$\text{As } e = M \frac{di}{dt} = M \frac{d}{dt} (i_0 \sin \omega t)$$

$$\therefore e = Mi_0 \cos \omega t(\omega)$$

$$e_{\text{max}} = Mi_0 \times 1 \times \omega$$

$$= 0.005 \times 10 \times 10\pi = 5\pi$$

349 (d)

The emf induced in a conductor does not depend on its shape, but only on its end points,  $M$  and  $Q$  in this case. Thus the conductor is equivalent to an imaginary straight conductor of  $l = MQ = 2R$ .

Therefore, potential difference developed across the ring  $= Blv = B(2R)v$ . And the direction of induced current is from  $Q$  to  $M$ . Therefore,  $Q$  is at higher potential.

350 (b)

$$L = \frac{e}{di/dt} = \frac{edt}{di} = \frac{5 \times 10^{-3}}{(3-2)} \text{ H} = 5 \text{ mH}$$

351 (a)

As  $M \propto N_1 N_2$ , therefore,  $M$  remains the same.

352 (b)

For purely capacitive circuit  $e = e_0 \sin \omega t$

$$i = i_0 \sin \left( \omega t + \frac{\pi}{2} \right), \text{ i.e., current is ahead of emf by}$$

$$\frac{\pi}{2}$$

353 (d)

$$\text{Current, } i = \frac{V}{\sqrt{R^2 + X_C^2}}$$

If a dielectric is introduced into the gap between the plates of capacitor. Its capacitance will

increase and hence, impedance of the circuit will decrease. Thus, current and hence brightness of the bulb increase.

354 (d)

When resonance occurs emf  $E$  and current  $i$  are in phase. In this case, the impedance is minimum and current is maximum. At resonance inductive reactance is equal to capacitive reactance

$$X_L = X_C$$

355 (c)

The circuit element connected to the AC source will be pure resistor. In pure resistive AC circuit, voltage and current are in the same phase

356 (b)

$$\text{Frequency} = \frac{1}{2\pi\sqrt{LC}}$$

So the combination which represents dimension of frequency is  $\frac{1}{\sqrt{LC}} = (LC)^{-1/2}$

357 (a)

In  $LCR$  series circuit, impedance  $Z$  of the circuit is given by

$$Z = \sqrt{(R)^2 + (X_L - X_C)^2} \text{ where } X_L = \omega L, X_C = 1/\omega C$$

At resonance  $X_L = X_C \therefore Z = R$

358 (c)

$$X_L = 2\pi f$$

$$\Rightarrow X_L \propto f$$

$$\Rightarrow \frac{1}{X_L} \propto \frac{1}{f}$$

i.e., graph between  $\frac{1}{X_L}$  and  $f$  will be a hyperbola

359 (d)

For current to be maximum,  $X_L = X_C$

Hence, resonant frequency

$$f = \frac{1}{2\pi} = \frac{1}{\sqrt{LC}} = \frac{1}{\sqrt{0.5 \times 8 \times 10^{-6}}} = \frac{10^3}{4\pi}$$

But angular frequency

$$\omega = 2\pi f$$

$$\omega = \frac{2\pi \times 1000}{4\pi} = 500 \text{ Hz}$$

360 (b)

The average power consumed in an AC circuit is given by

$$P = \frac{V_0 I_0}{2} \cos \phi$$

Where  $\phi$  is phase angle and  $V_0$  and  $I_0$  the peak value of voltage and current.

Given,  $V_0 = 200 \text{ V}$ ,  $I_0 = 2 \text{ A}$ ,  $\phi = \frac{\pi}{3}$ .

$$\begin{aligned} P &= \frac{200 \times 2}{2} \cos \frac{\pi}{3} \\ &= \frac{200 \times 2}{2} \times \frac{1}{2} = 100 \text{ W} \end{aligned}$$

361 (d)

The given circuit is under resonance as  $X_L = X_C$   
Hence, power dissipated in the circuit is

$$P = \frac{V^2}{R} = 242 \text{ W}$$

362 (c)

$$Z = \sqrt{R^2 + (2\pi\nu L)^2}$$

$$= \sqrt{(40)^2 + 4\pi^2 \times (50)^2 \times (95.5 \times 10^{-3})^2}$$

$$= 50 \text{ ohm}$$

363 (c)

$$i_L = \frac{90}{30} = 3 \text{ A}$$

$$i_C = \frac{90}{20} = 4.5 \text{ A}$$

Net current through circuit  $i = i_C - i_L = 1.5 \text{ A}$

$$\therefore Z = \frac{V}{i} = \frac{90}{1.5} = 60 \Omega$$

364 (c)

$$\therefore \phi = Mi$$

$$\therefore M = \frac{\phi}{i} = \frac{0.4}{2} = 0.2 \text{ H}$$

365 (c)

$$i = \frac{V}{X_L} = \frac{120}{2 \times 3.14 \times 60 \times 0.7} = 0.455 \text{ A}$$

366 (d)

$$\tan \phi = \frac{X_L}{R} = \frac{2\pi\nu L}{R} \Rightarrow \tan 30^\circ = \frac{2\pi \times 50 \times L}{\pi\sqrt{3}}$$

$$= 0.01 \text{ H}$$

367 (a)

For purely  $L$ -circuit  $P = 0$

369 (a)

$$R = 6 + 4 = 10 \Omega$$

$$X_L = \omega L = 2000 \times 5 \times 10^{-3} = 10 \Omega$$

$$X_C = \frac{1}{\omega C} = \frac{1}{2000 \times 50 \times 10^{-6}} = 10 \Omega$$

$$\therefore Z = \sqrt{R^2 + (X_L - X_C)^2} = 10 \Omega$$

$$\text{Amplitude of current} = i_0 = \frac{V_0}{Z} = \frac{20}{10} = 2 \text{ A}$$

370 (c)

$$\text{Impedance, } Z = \sqrt{(X_L - X_C)^2 + R^2}$$

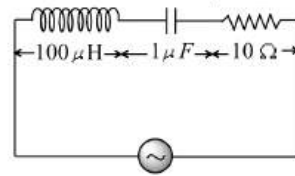

$$Z = \sqrt{\left(\omega L - \frac{1}{\omega C}\right)^2 + R^2}$$

Inductive reaction

$$X_L = \omega L = 70 \times 10^3 \times 100 \times 10^{-6} = 7 \Omega$$

Capacitance reactance

$$X_C = \frac{1}{\omega C} = \frac{1}{70 \times 10^3 \times 1 \times 10^{-6}}$$

$$= \frac{100}{7} \quad [X_C > X_L]$$

Hence, circuit behaves like an  $R$ - $C$  circuit

# ALTERNATING CURRENT

---

## Assertion - Reasoning Type

This section contain(s) 0 questions numbered 1 to 0. Each question contains STATEMENT 1(Assertion) and STATEMENT 2(Reason). Each question has the 4 choices (a), (b), (c) and (d) out of which **ONLY ONE** is correct.

- a) Statement 1 is True, Statement 2 is True; Statement 2 is correct explanation for Statement 1
- b) Statement 1 is True, Statement 2 is True; Statement 2 is **not** correct explanation for Statement 1
- c) Statement 1 is True, Statement 2 is False
- d) Statement 1 is False, Statement 2 is True

1

**Statement 1:** In a series  $R$ - $L$ - $C$  circuit the voltages across resistor, inductor and capacitor are 8 V, 16 V and 10 V respectively. The resultant emf in the circuit is 10 V.

**Statement 2:** Resultant emf of the circuit is given by the relation.  $E = \sqrt{V_R^2 + (V_L - V_C)^2}$

2

**Statement 1:** The capacitor blocks DC but allows AC.

**Statement 2:** The capacitor offers infinite resistance to DC.

3

**Statement 1:** The alternating current lags behind the  $e.m.f.$  by a phase angle of  $\pi/2$ , when ac flows through an inductor

**Statement 2:** The inductive reactance increases as the frequency of ac source decreases

4

**Statement 1:** In series  $L - C - R$  circuit resonance can take place

**Statement 2:** Resonance takes place if inductive and capacitive reactance are equal and opposite.

5

**Statement 1:** The mutual inductance of two coils is doubled if the self-inductance of the primary or secondary coil is doubled.

**Statement 2:** Mutual inductance is proportional to the self-inductance of primary and secondary coils.

6

**Statement 1:** The average value of alternating emf is 63.69% of the peak value.





**Statement 2:** The rms value of alternating emf is 70.72% of peak value.

7

**Statement 1:** An inductance and a resistance are connected in series with an ac circuit. In this circuit the current and the potential difference across the resistance lags behind potential difference across the inductance by an angle  $\pi/2$

**Statement 2:** In  $LR$  circuit voltage leads the current by phase angle which depends on the value of inductance and resistance both

8

**Statement 1:** Making or breaking of current in a coil produces no momentary current in the neighbouring coil of another circuit

**Statement 2:** At the time of making or breaking of current changes.

9

**Statement 1:** Inductance coil are made of copper.

**Statement 2:** Induced current is more in wire having less resistance

10

**Statement 1:** The divisions are equally marked on the scale of ac ammeter

**Statement 2:** Heat produced is directly proportional to the current

11

**Statement 1:** Two identical heaters are connected to two different sources one DC and other AC having same potential difference across their terminals. The heat produced in heater supplied with AC source is greater.

**Statement 2:** The et impedance of a AC source is greater than resistance.

12

**Statement 1:** When capacitive reactance is smaller than the inductive reactance in  $LCR$  circuit,  $e.m.f.$  leads the current

**Statement 2:** The phase angle is the angle between the alternating  $e.m.f.$  and alternating current of the circuit

13

**Statement 1:** If the frequency of alternating current in an ac circuit consisting of an inductance coil is increased then current gets decreased

**Statement 2:** The current is inversely proportional to frequency of alternating current

14

**Statement 1:** If a variable frequency AC source is connected to a capacitor, the displacement current in it increases with increase in frequency.

**Statement 2:** The increase in frequency results in an increase of impedance.

15

**Statement 1:** A capacitor of suitable capacitance can be used in an ac circuit in place of the choke coil



**Statement 2:** A capacitor blocks dc and allows ac only

16

**Statement 1:** Average value of ac over a complete cycle is always zero

**Statement 2:** Average value of ac is always defined over half cycle

17

**Statement 1:** Ac is more dangerous than dc

**Statement 2:** Frequency of ac is dangerous for human body

18

**Statement 1:** In a series  $R - L - C$  circuit the voltage across resistor, inductor and capacitor are 8V, 16V and 10V respectively. The resultant emf in the circuit is 10.

**Statement 2:** Resultant emf of the circuit is given by the relation  $E = \sqrt{V_R^2 + (V_L - V_C)^2}$

19

**Statement 1:** Capacitor serves as a block for dc and offers an easy path to ac

**Statement 2:** Capacitive reactance is inversely proportional to frequency

20

**Statement 1:** The armature current in DC motor maximum when the motor has just started.

**Statement 2:** Armature current is given by  $i = \frac{E - e}{R_a}$  Where  $e$  = the back emf and  $R_a$  = resistance of armature.

21

**Statement 1:** The energy stored in the inductor of 2 H, when a current of 10 A flows through it is 100 J.

**Statement 2:** Energy stored in an inductor is directly proportional to its inductance.

22

**Statement 1:** In a series  $R - L - C$  circuit the voltage across resistor, inductor and capacitor are 8 V, 16 V and 10 V respectively. The resultant emf the circuit is 10 V

**Statement 2:** Resultant emf of the circuit is given by the relation  $E = \sqrt{V_R^2 + (V_L - V_C)^2}$

23

**Statement 1:** For an electric lamp connected in series with a variable capacitor and ac source, its brightness increases with increase in capacitance

**Statement 2:** Capacitive reactance decreases with increase in capacitance of capacitor

24

**Statement 1:** A sinusoidal AC current flows through a resistance  $R$ . If the peak current is  $I_0$ , then the power dissipated is  $\frac{RI_0^2}{2}$ .

**Statement 2:** For purely resistive circuit, power factor  $\cos \phi = 1$ .



## ALTERNATING CURRENT

### : ANSWER KEY :

1)	a	2)	a	3)	c	4)	a	17)	a	18)	a	19)	a	20)	b
5)	c	6)	b	7)	b	8)	d	21)	b	22)	a	23)	a	24)	b
9)	b	10)	d	11)	a	12)	b								
13)	a	14)	c	15)	b	16)	b								



# ALTERNATING CURRENT

## : HINTS AND SOLUTIONS :

1 (a)

The resultant emf in the  $L - C - R$  circuit is given by

$$E = \sqrt{V_R^2 + (V_L - V_C)^2}$$

$$E = \sqrt{(8)^2 + (16 - 10)^2}$$

$$E = \sqrt{64 + 36} \Rightarrow E = 10V$$

2 (a)

From the formula the capacitive reactance is

$$X_C = \frac{1}{\omega C} = \frac{1}{2\pi f C}$$

Where  $\omega$  represents angular frequency,  $C$  for capacitance and  $f$  represent the frequency.

The frequency of DC is zero hence capacitive reactance becomes infinity. When the same capacitor is connected with AC, capacitive reactance is not equal to infinity hence capacitor allows AC to pass through it, and offers infinite resistance to DC.

3 (c)

When ac flows through an inductor, current lags behind the *emf* by phase of  $\pi/2$ . Inductive reactance,  $X_L = \omega L = \pi \cdot 2f \cdot L$ , so when frequency increases correspondingly inductive reactance also increases

4 (a)

Resonance in  $L - C - R$  series circuit takes place when inductive reactance and capacitive reactance are equal and opposite *ie*,

$$X_L = X_C$$

$$\text{Or } \omega_0 L = \omega_0 C$$

$$\text{Or } \omega_0 = \frac{1}{\sqrt{LC}} \quad \text{or } f_0 = \frac{1}{2\pi\sqrt{LC}}$$

In other words we can say that at resonant

frequency ( $f_0 = \frac{1}{2\pi\sqrt{LC}}$ ) resonance can take place.

5 (c)

It two coil of inductance  $L_1$  and  $L_2$  are joined together, then their mutual inductance is given by

$$M = k\sqrt{L_1 L_2}$$

It is clear from the relation, if self-inductance of primary and secondary coil are doubled the mutual inductance of the coils will be doubled.

6 (b)

The average value of alternating emf  $E = E_0 \sin \omega t$  over a positive half cycle is

$$E_{\text{av half cycle}} = \frac{2E_0}{\pi} = 0.6369$$

$$\text{Percentage of } E_{\text{av}} = 0.6369 \times 100 = 63.69\%$$

Also rms value of emf is given as

$$E_{\text{rms}} = \frac{E_0}{\sqrt{2}} = 0.7072$$

$$\text{Percentage } E_{\text{rms}} = 0.7072 \times 100 = 70.72\%$$

7 (b)

As both the inductive and resistance are joined in series, hence current through both will be same. But in case of resistance, both the current and potential vary simultaneously, hence they are in same phase. In case of an inductance when current is zero, potential difference across it is maximum and when current reaches maximum (at  $\omega t = \pi/2$ ), potential difference across it becomes zero, *i. e.*, potential difference leads the current by  $\pi/2$  or current lags behind the potential difference by  $\pi/2$ . Phase angle in case of LR circuit is given as  $\phi = \tan^{-1} \left( \frac{\omega L}{R} \right)$



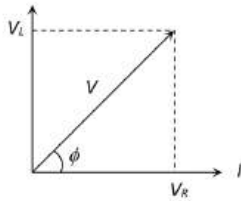

8 **(d)**  
Before making current in a coil, the current is zero and before breaking the current is maximum. In other words, it is constant in both the cases. Obviously, on making or breaking the current in a circuit, the current starts changing. The changing current produces changing magnetic field, which in turn produces induced current in the neighbouring coil of the circuit.

9 **(b)**  
Since, copper consists of a very small ohmic resistance so, inductance coils are made of copper. A large induced current is produced in such an inductance due to change in flux, which offers a pretty opposition to the flow of current.

10 **(d)**  
An ac ammeter is constructed on the basis of heating effect of the electric current. Since heat produced varies as square of current ( $H = I^2 R$ ), therefore the division marked on the scale of ac ammeter are not equally spaced

11 **(a)**  
For the case of DC, the frequency is zero and the net impedance is equal to the resistance.

For the case of AC, the impedance of the AC circuit is given by

$$Z = \sqrt{R^2 + \omega^2 L^2}$$

Where  $R$  = resistance,  $\omega$  = angular frequency and  $L$  = inductance.

12 **(b)**  
The phase angle for the LCR circuit is given by

$$\tan \phi = \frac{X_L - X_C}{R} = \frac{\omega L - 1/\omega C}{R}$$

Where  $X_L, X_C$  are inductive reactance and capacitive reactance respectively. When  $X_L > X_C$  then  $\tan \phi$  is positive, i. e.,  $\phi$  is positive (between 0 and  $\pi/2$ ). Hence emf leads the current

13 **(a)**  
When frequency of alternating current is increasing, the effective resistance of the

inductive coil increases. Current ( $X_L = \omega L = 2\pi fL$ ) in the circuit containing inductor is given by  $I = \frac{V}{X_L} = \frac{V}{2\pi fL}$ . As inductive resistance of the inductor increases, current in the circuit decreases

14 **(c)**  
The impedance of a capacitor is given by

$$X_C = \frac{1}{2\pi fC}$$

$$\Rightarrow X_C \propto \frac{1}{f}$$

Thus, the impedance of the capacitor decreases with increase in the frequency  $f$  of a source.

Current now increase in the capacitor with decrease of impedance or resistance. This is equal to displacement current between the plates of capacitor.

15 **(b)**  
We can use a capacitor of suitable capacitance as a choke coil because average power consumed per cycle in an ideal capacitor is zero. Therefore, like a choke coil, a condenser can reduce ac without power dissipation

16 **(b)**  
The mean average value of alternating current (or emf) during half cycle is given by  $I_m = 0.636 I_0$  (or  $E_m = 0.636 E_0$ )

During the next half cycle, the mean value of ac will be equal in magnitude but opposite in direction

For this reason the average value of ac over a complete cycle is always zero. So the average value is always defined over a half cycle of ac

17 **(a)**  
It is because for a given value of voltage, peak value of ac voltage is greater than the dc voltage. For e. g., In case of 220 V ac,  $V_0 = 220\sqrt{2} = 311$  V  $\therefore$  311 V will cause more harm to the human body than 220 V dc

18 **(a)**  
The resultant emf in the L - C - R circuit is given by

$$E = \sqrt{V_R^2 + (V_L - V_C)^2}$$

$$E = \sqrt{(8)^2 + (16 - 10)^2}$$

$$= \sqrt{64 + 36}$$

$$E = 10 \text{ V}$$

19 (a)

The capacitive reactance of capacitor is given by

$$X_C = \frac{1}{\omega C} = \frac{1}{2\pi f C}$$

So this is infinite for dc ( $f = 0$ ) and has a very small value of ac. Therefore a capacitor blocks dc

20 (b)

From the relation

$$i = \frac{E - e}{R_a}$$

When the motor is started  $e = 0$

$$\text{Hence, Eq (i) becomes } i_{\text{start}} = \frac{E}{R_a}$$

It is obvious that current is maximum when the motor has just started.

21 (b)

The energy stored in the inductor is given by

$$V = \frac{1}{2} Li_0^2 = \frac{1}{2} \times 2 \times (10)^2 = 100 \text{ J}$$

It is obvious that energy stored is directly proportional to its inductance.

22 (a)

The resultant emf in the L-C-R circuit is given by

$$E = \sqrt{V_R^2 + (V_L - V_C)^2}$$

$$E = \sqrt{(8)^2 + (16 - 10)^2}$$

$$= \sqrt{64 + 36}$$

$$E = 10 \text{ V}$$

23 (a)

Capacitive reactance  $X_C = \frac{1}{\omega C}$ . When capacitance ( $C$ ) increases, the capacitive reactance decreases. Due to decrease in its values, the current in the

circuit will increase  $\left( I = \frac{E}{\sqrt{R^2 + X_C^2}} \right)$  and hence

brightness of source (or electric lamp) will also increase

24 (b)

Power dissipated is given by

$$P = E_{\text{rms}} I_{\text{rms}} \cos \phi$$

We know that for purely resistance circuit power factor  $\cos \phi = \frac{R}{Z} = \frac{R}{R} = 1$

Hence,  $P = E_{\text{rms}} \times I_{\text{rms}}$

$$= (RI_{\text{rms}}) \times I_{\text{rms}}$$

$$= R (I_{\text{rms}})^2$$

$$= R \left( \frac{I_0}{\sqrt{2}} \right)^2 = \frac{RI_0^2}{2}$$

# ALTERNATING CURRENT

## Matrix-Match Type

This section contain(s) 0 question(s). Each question contains Statements given in 2 columns which have to be matched. Statements (A, B, C, D) in **columns I** have to be matched with Statements (p, q, r, s) in **columns II**.

1. You are given many resistances, capacitors and inductors. These are connected to a variable DC voltage source (the first two circuits) or an AC voltage source of 50 Hz frequency (the next three circuits) in different ways as shown in Column-II. When a current  $I$  (steady state for DC or *rms* for AC) flows through the circuit, the corresponding voltage  $V_1$  and  $V_2$  (indicated in circuits) are related as shown in Column-I. Match the two

Column-I

Column-II

(A)  $I \neq 0, V_1$  is proportional to  $I$

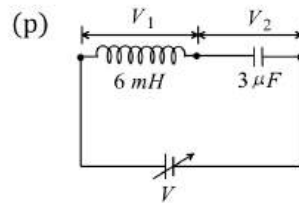

(B)  $I \neq 0, V_2 > V_1$

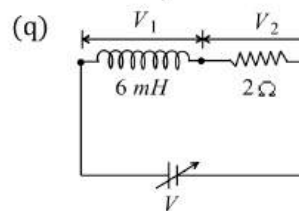

(C)  $V_1 = 0, V_2 = V$

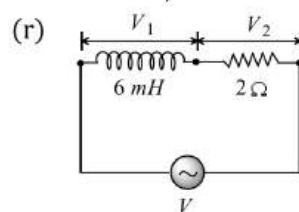

(D)  $I \neq 0, V_2$  is proportional to  $I$

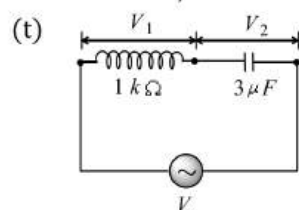
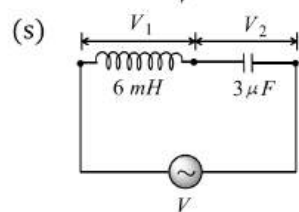

**CODES :**



	A	B	C	D
a)	r,s,t	q,r,s,t	p,q	q,r,s,t
b)	q,r,s,t	p,q	r,s,t	q,r
c)	p,q	r,s,t	q,r,s,t	s,t
d)	r,s,t	p,q	q,r,s,t	q,r,s,t





## ALTERNATING CURRENT

---

**: ANSWER KEY :**

1) a

|



# ALTERNATING CURRENT

## : HINTS AND SOLUTIONS :

1 (a)

As per given conditions, there will be no steady state in circuit 'p', so it should not be considered in options of 'C'

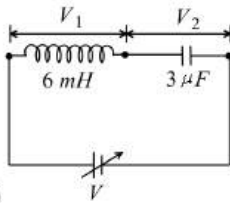

(p)

As  $I$  is steady state current

$$V_1 = 0; I = 0$$

Hence,  $V_2 = V$

So, of p  $\Rightarrow$  C

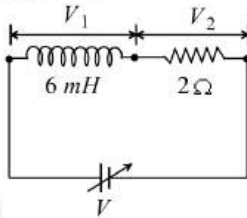

(q)

In the steady state;

$$V_1 = 0 \text{ as } \frac{di}{dt} = 0$$

$$\therefore V_2 = V = IR \text{ or}$$

$$V_2 \propto I$$

and  $V_2 > V_1$

So, of q  $\Rightarrow$  B, C, D

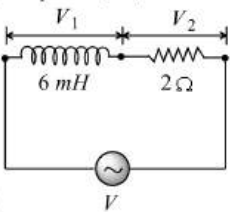

(r)

Inductive reactance

$$X_L = \omega L$$

$$X_L = 6\pi \times 10^{-1} \Omega \text{ and resistance}$$

$$= R = 2\Omega$$

$$\text{So, } V_1 = IX_L \text{ and } V_2 = IR$$

$$\text{Hence, } V_2 > V_1$$

So, of r  $\Rightarrow$  A, B, D

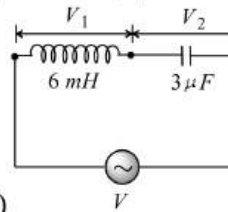

(s)

Here,  $V_1 = IX_L$ , where  $X_L = 6\pi \times 10^{-1} \Omega$

Also,  $V_2 = IX_C$ , where

$$X_C = \frac{10^4}{3\pi}$$

So,  $V_2 > V_1$

$$V_1 \propto I$$

$$V_2 \propto I$$

So, of s  $\Rightarrow$  A, B, D

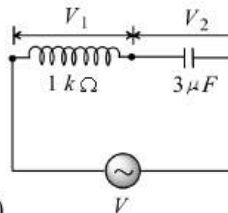

(t)

Here,  $V_1 = IR$ , where

$$R = 1000\Omega,$$

$$X_C = \frac{10^4}{3\pi} \Omega$$

$$V_2 = IX_C,$$

So,  $V_2 > V_1$  and  $V_1 \propto I; V_2 \propto I$

So, of t  $\Rightarrow$  A, B, D

**Note:** for circuit 'p'

$$V - \frac{Ldi}{dt} - \frac{q}{c} = 0 \text{ or } CV = CL \frac{di}{dt} + q \text{ or } 0 = LC \frac{d^2i}{dt^2} + \frac{dq}{dt}$$

$$\text{or } \frac{d^2i}{dt^2} = -\frac{1}{LC} \frac{dq}{dt}$$

$$\text{So, } i = i_0 \sin\left(\frac{1}{\sqrt{LC}}t + \phi_0\right)$$

As per given conditions, there will be no steady state in circuit 'p'. So it should not be considered in options of 'C'

$$\therefore (A) \rightarrow r,s,t; (B) \rightarrow q,r,s,t; (C) \rightarrow p,q; (D) \rightarrow q,r,s,t$$